

CENTER[®] 200

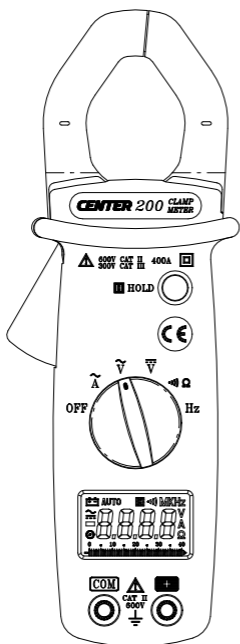

Instruction Manual



MINI AC CLAMP METER

CONTENTS

<i>TITLE</i>	<i>PAGE</i>
I. Safety Information	1
Environmental Conditions.....	1
Explanation of Symbols.....	1
II. Specification	2
General Specification.....	2
Electrical Specification.....	3
III. Instrument Familiarization	4
Symbol Definition.....	5
IV. Measuring Instruction	6
4.1 ACV measurement.....	6
4.2 ACV measurement.....	7
4.3 DCV measurement.....	8
4.4 Resistance measurement.....	9
4.5 Continuity Test.....	10
4.6 Frequency measurement from the terminals.....	11
4.7 Frequency measurement with the clamp.....	12
V. Battery Changing	13
VI. Maintenance	14

I. Safety Information

Do not operate the tester if the body of meter or the test lead look broken.

Check the main function dial and make sure it is at the correct position before each measurement.

Do not perform resistance and continuity test on a live power system.

Do not apply voltage between the test terminals and test terminal to ground that exceed the maximum limit record in this manual.

Exercise extreme caution when measuring live system with voltage greater than 60V DC or 30V AC.

Keep the fingers after the protection ring when measuring through the test lead.

Change the battery when the  symbol appears to avoid incorrect data.

Environmental Conditions:

Altitude up to 2000 meters.



Operating temperature: 0°C ~ 40°C, <80% RH, non-condensing

Storage temperature: -10°C ~ 60°C, <70% RH, battery removed

Pollution Degree: 2

Installation Categories II

Explanation of Symbols:

-  Attention! Refer to operation Instructions.
-  Dangerous voltage may be present at terminals.
-  This instrument has double insulation.

Approvals:  EN61010 600V CAT II 300V CAT III

II. Specification

General Specification:

Digital Display:

3 3/4 digits LCD display with maximum reading 3999

Analog Display:

42 segments fast analog bar display

Symbol and Scale range:

adjust automatically according range and input signal

Polarity:

When negative signal in apply to the tester,  will show.

Over Load:

When the signal larger than the maximum will be show 

Sample Rate:

2 times/sec for digital data

20 times/sec for analog bar

Low Power Indication:

When the battery is under the proper operation range,  will appear on the LCD display.

Power Source: UM-4 or AAA 1.5V battery x 2.

Auto Power Off:

If there is no key or dial operation for 30 minutes, the meter will power itself off to save battery consumption.

Clamp opening size: 25mm

Dimension (L x W x H) :

193 x 50 x 28mm, 7.60 x 1.97 x 1.1 inch

Weight: 230g, 8.11OZ (include battery)

Accessory:

Instruction Manual, Leather Case, Test lead, Battery 1.5Vx2

Battery Life: 250 hr approx. (alkaline battery)

Electrical Specification:

The accuracy specification is defined as $\pm(\dots\% \text{reading} + \dots \text{count})$

At $23 \pm 5^\circ\text{C}$, $\leq 80\% \text{RH}$

DCV (Autorange)

Range	Resolution	Accuracy	Input Impedance	Overload Protection
400V	0.1V	1%+2	1M Ω	660Vrms
600V	1V			

ACV (Autorange)

Range	Resolution	Accuracy	Input Impedance	Overload Protection
		50Hz~500Hz		
400V	0.1V	1.5%+5	1M Ω	660Vrms
600V	1V			

ACA (Autorange)

Range	Resolution	Accuracy		Overload Protection
		50Hz~60Hz	60Hz~500Hz	
40A	0.01A	50Hz~60Hz	60Hz~500Hz	600Arms
400A	0.1A	1.9%+5	2.5%+5	

Ohm (Ω)

Range	Resolution	Accuracy	MAX Test Voltage	Overload Protection
400 Ω	0.1 Ω	1%+2	1.5VDC	600Vrms

Continuity (•••)

Range	Active Region	MAX Test Voltage	Overload Protection
•••	<40 Ohm	1.5 VDC	600Vrms

Frequency (Hz) (Autorange)

Function	Range	Resolution	Accuracy	Sensitivity	Overload Protection
Current Frequency	20Hz - 4KHz	1Hz	0.1%+1	2Arms	600Arms
	10KHz	10Hz			
Voltage Frequency	10Hz-4KHz	1Hz	0.1%+1	3Vrms	600Vrms
	40KHz	10Hz			
	400KHz	100Hz		5Vrms	
	1MHz	1KHz			

III. Instrument Familiarization:

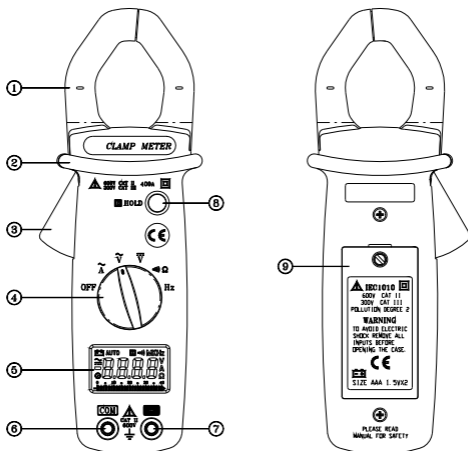

- ① Current Sensing Clamp
- ② Safety protection ring
- ③ Clamp opening handle
- ④ Function select dial
- ⑤ LCD display
- ⑥ COM input terminal
- ⑦ Positive input terminal
- ⑧ Data hold button
- ⑨ Battery cabinet

Symbol Definition:



Low battery indication

AUTO

Auto range indication



Manual range indication



Hold Data indication



Continuity function indication

V

Voltage measurement indication

A

Current measurement indication



Alternative source indication



Direct source indication



Polarity indication



Analog bar graph indication

MK Hz

Frequency Measurement indication

IV. Measuring Instruction:

4.1 ACA measurement:

Switch the main function selector to **A** \sim range.

Open the clamp by pressing the jaw-opening handle and insert the cable to be measured into the jaw.

Close the clamp and get the reading from the LCD panel.

Note:

Before this measurement, disconnect the test lead with the meter for safety.

In some occasion that the reading is hard to read, push the HOLD button and read the result later.

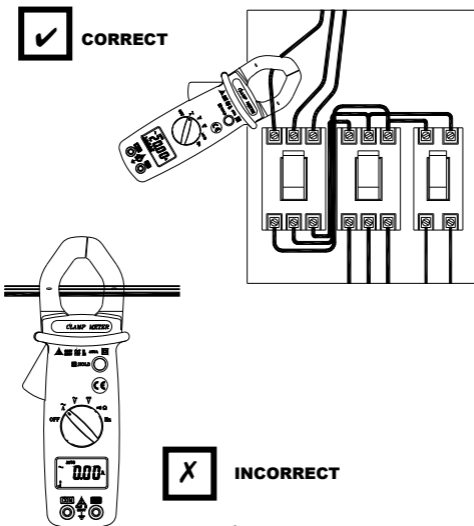

4.2 ACV measurement:

Switch the main function selector to $V \sim$ range.

Connect red test lead to “+” terminal and black one to the “COM” terminal.

Measure the voltage by touch the test lead tips to the test circuit where the value of voltage is needed.

Read the result from the LCD panel.

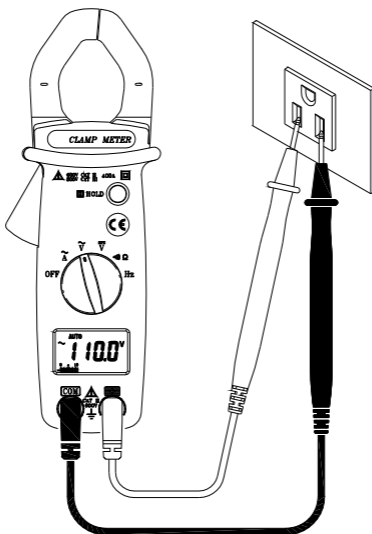

4.3 DCV measurement:

Switch the main function selector to **V** --- range.

Connect red test lead to “+” terminal and black one to the “COM” terminal.

Measure the voltage by touch the test lead tips to the test circuit where the value of voltage is needed.

Read the result from the LCD panel.

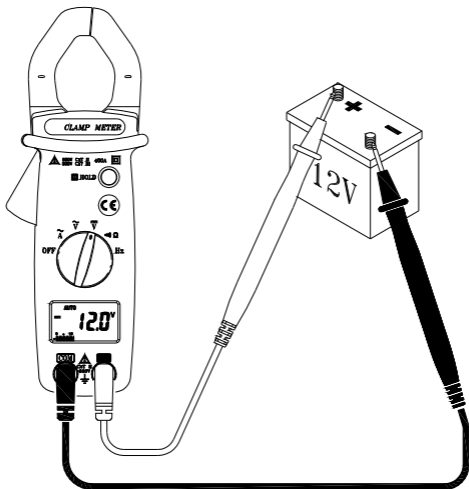

4.4 Resistance measurement:

Switch the main function to Ω range.

Connect red test lead to “+” terminal and black one to the “COM” terminal.

Connect tip of the test leads to the points where the value of the resistance is needed.

Read the result from the LCD panel.

Note:

When take resistance value from a circuit system, make sure the power is cut off and all capacitors need to be discharged

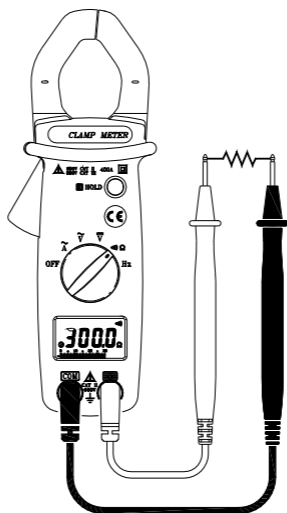

4.5 Continuity Test:

Switch the main function to  range.

Connect red test lead to “+” terminal and black one to the “COM” terminal.

Connect tip of the test leads to the points where the conduction condition needed.

If the resistance is under $40\ \Omega$, the beeper will sound continuously.

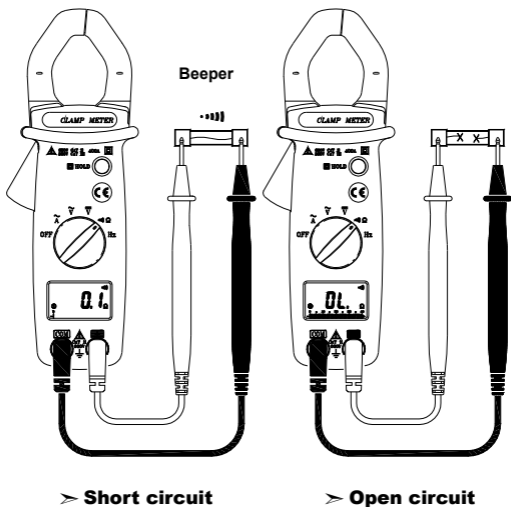

4.6 Frequency measurement from the terminals:

Switch the main function to “ Hz ” range.

Connect red test lead to “+” terminal and black one to the “ COM ” terminal.

Connect tip of the test leads to the points where the value of the resistance is needed.

Connect tip of the test leads to the points where the frequency of the voltage signal is needed.

Read the Result from the LCD panel.

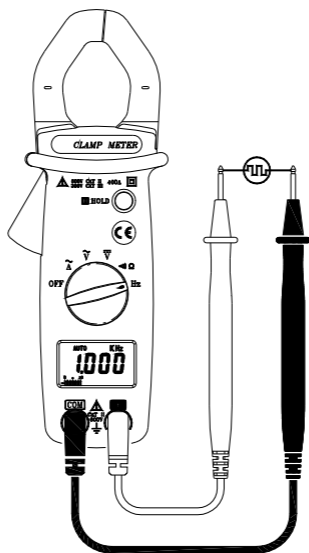

4.7 Frequency measurement with the clamp:

Switch the main function selector to “ Hz ” range.

Open the clamp by pressing the clamp-opening handle and insert the cable to be measured into the clamp.

Close the clamp and get the reading form the LCD panel.

Note:

When doing frequency measurement, user should either use the terminal signal or clamp signal but not both. If both sources are applied an error will occur.

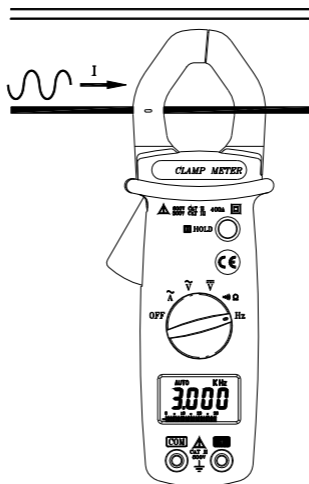

V. Battery Changing:

1. When the battery voltage drop below proper operation range the  symbol will appear on the LCD display and the battery need to be changed.
2. Before changing the battery, switch the main dial to "OFF" and disconnect test leads.
Open the cover of the battery cabinet by a screwdriver.
Replace the old batteries with two UM-4 or AAA size batteries.
3. Close the battery cabinet cover and fasten the screw.

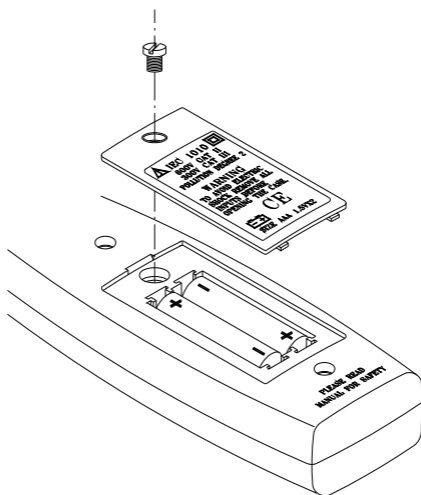

VI. Maintenance:

WARNING!

Before open the battery door, disconnect both test lead and never uses the meter before the battery door is closed.

CAUTION

To avoid contamination or static damage, do not touch the circuit board without proper static protection.

REMARK

- * If the meter is not going to be used for a long time, take out the battery and do not store the meter in high temperature or high humidity environment.
- * When take current measurement, keep the cable at the center of the clamp will get more accurate test result.
- * Repairs or servicing not covered in this manual should only by qualified personal.

CLEANING

Periodically wipe the case with a dry cloth and detergent. Do not use abrasives or solvents on this instrument.

CENTER[®] CENTER TECHNOLOGY CORP.

4 / F NO. 415, Jung-Jeng Rd., 238 Shu-Lin, Taipei, Taiwan

TEL : 886-2-26763926 E-Mail : center@centertek.com

FAX : 886-2-26763925 [http : // www.centertek.com](http://www.centertek.com)

200-02
