

CENTER[®] 21 SMART CLAMP METER



Instruction Manual

CENTER TECHNOLOGY CORP.

4F, NO. 415, Jung-Jeng Rd., Shu-Lin Dist., New Taipei City 238, Taiwan
E-Mail: center@centertek.com
http://www.centertek.com

GCA000021-12000

Battery Changing

- When the battery voltage drops below proper operation range, the symbol will appear on the LCD display and the battery needs to be changed.
- Before changing the battery, switch the main dial to "OFF" and disconnect test leads.
- Open the cover of the battery cabinet by a screwdriver. Replace the old batteries with two UM-4 or AAA size batteries.
- Close the battery cabinet cover and fasten the screw.

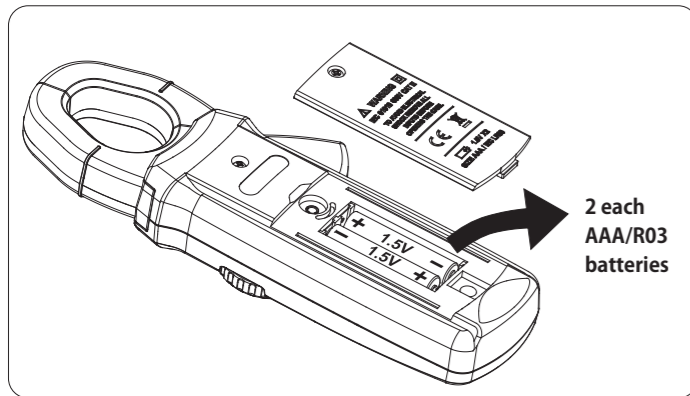

2 each
AAA/R03
batteries

2 Safety Information

- Do not operate the tester if the body of meter or the test lead looks broken.
- Check the main function dial and make sure it is at the correct position before each measurement.
- Do not perform resistance and continuity test on a live power system.
- Do not apply voltage between the test terminals and test terminal to ground that exceed the maximum limit record in this manual.
- Exercise extreme caution when measuring live system with voltage greater than 60V DC or 30V AC.
- Keep the fingers after the protection ring when measuring through the test lead.

Environmental Conditions:

- Altitude up to 2000 meters.
- Operating temperature: 0°C ~ 40°C, <80% RH, non-condensing
- Storage temperature: -10°C ~ 60°C, <70% RH, battery removed
- Pollution Degree: 2

Explanation of Symbols:

- Attention! Refer to operation instructions.
- Dangerous voltage may be present at terminals.
- This instrument has double insulation.

Approvals: EN61010 600V CAT III

Specifications

● GENERAL SPECIFICATION:

Display: 3 5/6 digits LCD display with maximum reading 5999.

Symbol and Scale range:

Adjust automatically according range and input signal.

Automatic Scanning:

AC/DC voltage measurement;
Resistance / Diode / Capacitance measurement.

Polarity: When negative signal is applied to the tester, will show.

Over Load: When the signal larger than the maximum will be shown .

Sample Rate: 2 times/sec for digital data.

Low Power Indication:

When the battery is under the proper operation range, will appear on the LCD display.

Power Source: UM-4 or AAA 1.5V battery x 2

Typical Battery Life:

200 hours approx. (alkaline battery)

Auto Power Off:

If there is no key or dial operation for 10 minutes, the meter will power itself off to save battery consumption.

Disable Auto Power Off:

To disable the function, press the "Hz" button or button and keep it pressed while powering on the meter. The indicator will not be displayed.

Clamp opening size: 25.4 mm (1")

Dimension / Weight: 203(L)x75(W)x32(H)mm / 270g, 9.53oz (include battery)

Accessory: Instruction Manual, Test lead, Battery 1.5Vx2

Symbol Definition & Button Location

1. Name of Parts & Position:



- ① Current sensing clamp
- ② NCV sensing area
- ③ Safety protection ring
- ④ Clamp opening handle
- ⑤ Function select dial
- ⑥ Backlight button
- ⑦ Frequency button
- ⑧ Data hold button
- ⑨ LCD display
- ⑩ COM input terminal
- ⑪ Positive input terminal
- ⑫ Battery compartment cover

2. LCD Display:

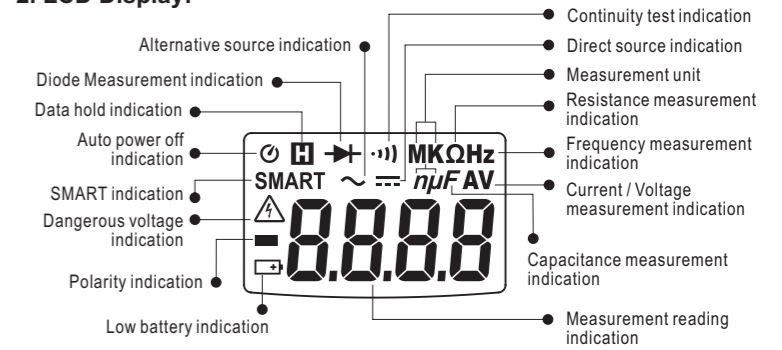

Maintenance

⚠ WARNING & CAUTION!

- Before opening the battery door, disconnect both test leads and never use the meter if the battery door is open.
- To avoid contamination or static damage, do not touch the circuit board without proper static protection.

REMARK:

If the meter is not going to be used for a long time, take out the battery and do not store the meter in high temperature or high humidity environment.

When taking current measurement, keep the cable at the center of the clamp to get more accurate test result.

Repairs or servicing not covered in this manual should be performed only by qualified person.

CLEANING:

Periodically wipe the case with a dry cloth and detergent.
Do not use abrasives or solvents on this instrument.

● ELECTRICAL SPECIFICATION:

The accuracy specification is defined as $\pm(\dots\% \text{reading} + \dots \text{count})$ at 23 \pm 5°C, \leq 80%RH

DCV (Autorange)

Range	Resolution	Accuracy	Input Impedance	Overload Protection
6V	0.001V	$\pm 1\% + 3 \text{dpts}$	10M Ω	600Vrms
60V	0.01V			
600V	0.1V			

ACV (Autorange)

Range	Resolution	Accuracy	Input Impedance	Overload Protection
6V	0.001V	$\pm 1.2\% + 5 \text{dpts}$	10M Ω	600Vrms
60V	0.01V			
600V	0.1V			

Note: minimum AC voltage measurement range: 0.2Vrms

ACA (Autorange)

Range	Resolution	Accuracy		Overload Protection
		50Hz~60Hz	60Hz~400Hz	
60A	0.01A	$\pm 1.9\% + 5 \text{dpts}$	$\pm 3.0\% + 5 \text{dpts}$	700Arms
600A	0.1A			

Ohm (Ω) (Autorange)

Range	Resolution	Accuracy	Max. Test Voltage	Overload Protection
600 Ω	0.1 Ω	$\pm 1.2\% + 3 \text{dpts}$	-1.5V DC	450Vrms
6K Ω	0.001K Ω			
60K Ω	0.01K Ω			
600K Ω	0.1K Ω			
6M Ω	0.001M Ω			

Continuity ($\cdot\cdot\cdot$)

Range	Active Region	Max Test Voltage	Overload Protection
$\cdot\cdot\cdot$	$\leq 30 \text{ Ohm}$	-1.5V DC	450Vrms

Diode (\rightarrow)

Range	Resolution	Max. Test Current	Test Voltage	Overload Protection
\rightarrow	1mV	<1mA	<1.2V	450Vrms

Frequency (Hz)(Autorange)

Function	Range	Resolution	Accuracy	Sensitivity	Overload Protection
Current Frequency	6KHz	0.001KHz	$\pm 0.2\% + 2 \text{dpts}$	2Arms	700Arms
	10KHz	0.01KHz			
Voltage Frequency	6KHz	0.001KHz	$\pm 0.2\% + 2 \text{dpts}$	5Vrms	600Vrms
	60KHz	0.01KHz			
	100KHz	0.1KHz			

Capacitance (\rightarrow)(Autorange)

Range	Resolution	Accuracy	Max. Test Voltage	Overload Protection
6nF	0.001nF	$\pm 3\% + 10 \text{dpts}$	-1.5V DC	450Vrms
60nF	0.01nF			
600nF	0.1nF			
6 μ F	0.001 μ F			
60 μ F	0.01 μ F			
600 μ F	0.1 μ F			

Note: minimum capacitance measurement range: 0.3nF

NCV sense:

Volt sense indication bar with beep should be on at 90Vac@ 1inch(2.54cm)

Measuring Instructions

(1) ACA measurement:

Switch the main function selector to \tilde{A} range.
 Open the clamp by pressing the jaw-opening handle, and then insert the cable to be measured into the jaw.
 Close the clamp and get the reading from the LCD panel.

Note:
 Before this measurement, disconnect the test lead with the meter for safety.
 In some occasion that the reading is hard to read, push the **HOLD** button and read the result later.

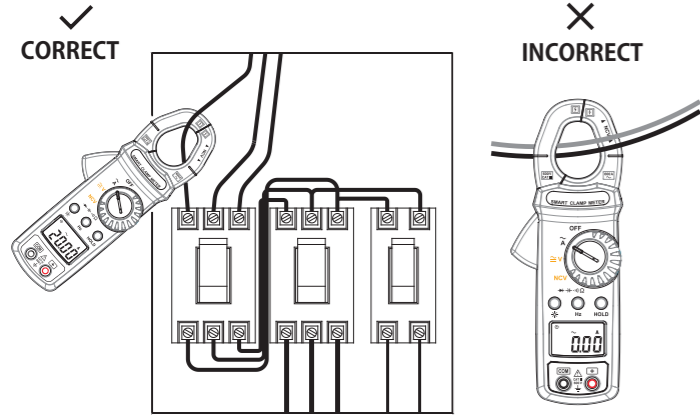

(8) Measurement Of The Voltage Frequency:

Switch the main function selector to \tilde{V} range.
 Press the **Hz** button. Annunciate and "K Hz" will appear on the display.
 Connect red test lead to "+" terminal and black one to the "COM" terminal.
 Place the touch prods in contact with the point whose frequency is to be measured.
 Read the result from the LCD panel.

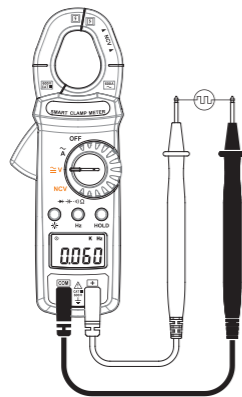

(9) Measurement Of The Current Frequency:

Switch the main function selector to \tilde{A} range.
 Press the **Hz** button. Annunciate and "K Hz" will appear on the display.
 Open the clamp by pressing the trigger.
 Encircle the conductor and close the jaws correctly by releasing the trigger.
 Read the result from the LCD panel.

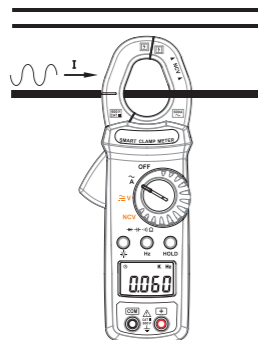

Note:
 Do not clamp over 2 or more wires at the same time. Irregular results will occur.

(2) ACV measurement:

Switch the main function selector to \tilde{V} range.
 Connect red test lead to "+" terminal and black one to the "COM" terminal.
 Measure the voltage by touching the test lead tips to the test circuit where the value of voltage is needed.
 Read the result from the LCD panel.

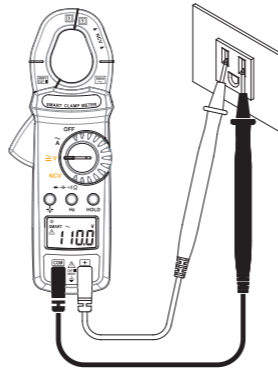

(3) DCV measurement:

Switch the main function selector to \tilde{V} range. Connect red test lead to "+" terminal and black one to the "COM" terminal.
 Measure the voltage by touching the test lead tips to the test circuit where the value of voltage is needed.
 Read the result from the LCD panel.

Note:
 When the reading is exceeding 30V in ACV or DCV, the Δ symbol will be displayed on.

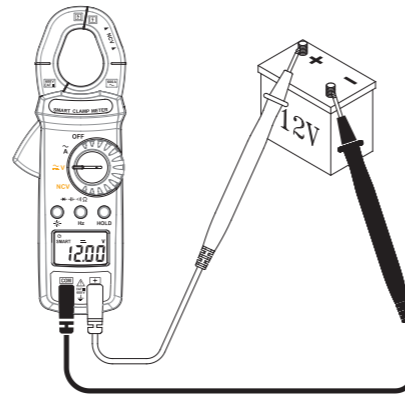

(10) Non-Contact Voltage (NCV):

⚠ DANGER!
The LCD and beeper may not be displayed due to installation condition of electrical circuit or equipment. Never touch the circuit under test to avoid possible danger even if the LCD and beeper for NCV is not displayed. Check the functionality of LCD and beeper on a well-known power supply prior to measurement. When the LCD and beeper doesn't indicate, do not make measurement.
NCV indication is affected by external voltage, and how the meter is held or placed.

Switch the main function selector to **NCV** range.
 Annunciate and "EF" will appear on the display.
 When no or less electric field is detected, the LCD shows "EF".
 If the detector senses electric field, the strength will be showed on LCD by "—" with beep no digits type. Level 1(weak) is "—" and the level 4(strong) is "----".
 The beeper frequency depends on the strength of electric field also. Place the edge of the jaw labeled "▲ NCV ▲" near the electric field.

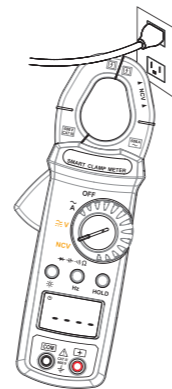

(4) Resistance measurement:

Switch the main function to Ω range.
 Connect red test lead to "+" terminal and black one to the "COM" terminal.
 Connect tip of the test leads to the points where the value of the resistance is needed.
 Read the result from the LCD panel.

Note:
 When taking resistance value from a circuit system, make sure the power is cut off and all capacitors need to be discharged.

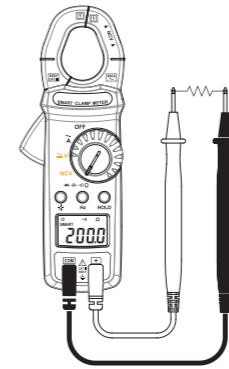

(5) Continuity Test:

Switch the main function to Ω range. Connect red test lead to "+" terminal and black one to the "COM" terminal. Connect tip of the test leads to the points where the conduction condition needed.
 If the resistance is under 30 Ω , the beeper will sound continuously.

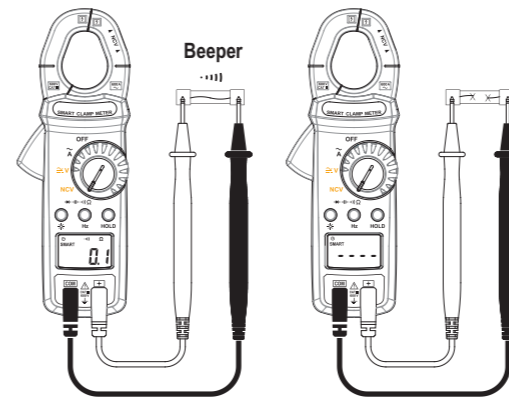

Button Instructions

- Back Light Button:**
 Press the button to turn on back-light.
 Press the button again to turn off back-light. The back-light will also be turned off automatically after 30 seconds to extend battery life.
- Data Hold Button:**
 Press the **HOLD** button to hold data.
 Press the **HOLD** button again to release held data.
- Hz Button:**
 Press the **Hz** button to annunciate Hz mode. And "K Hz" will appear on the display.
 Press the **Hz** button again to exit the Hz mode.
Note:
 This meter is built with Hz function at ACA, ACV ranges.

(6) Capacitance measurement:

Switch the main function selector to Ω range.
 Connect red test lead to "+" terminal and black one to the "COM" terminal.
 Connect tips of the test leads to the capacitor being tested.
 Read the result from the LCD panel.

Note:
 To avoid damage to the meter, disconnect circuit power and discharge all capacitors before measuring capacitance. Use the DC voltage function to confirm that the capacitor is discharged.

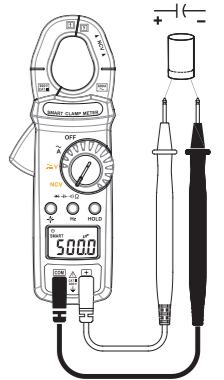

(7) Diode Test:

Switch the main function selector to Ω range.
 Connect red test lead to anode side and black test lead to the cathode side of the diode being tested. Read forward Voltage (Vf) value on LCD.
 If the polarity of the test leads are reversed with diode polarity, the digital reading shows "OL". This can be used for distinguishing anode and cathode terminals of a diode.

Note:
 Before taking any in-circuit measurement, remove power from the circuit being tested and discharge all capacitors in the circuit.

