

# CENTER<sup>®</sup> 211

CE

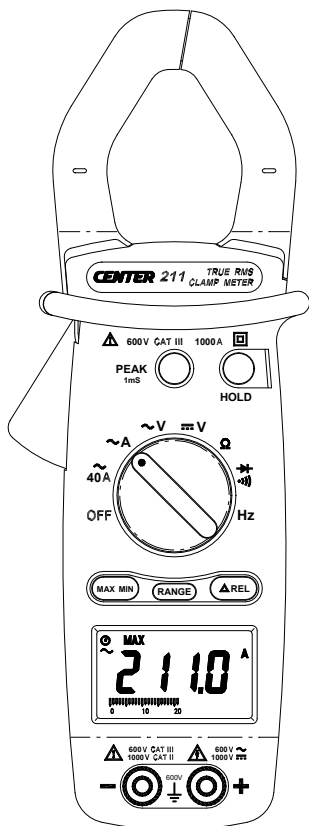

## Instruction

## Manual

# TRMS CLAMP METER

# CONTENTS

---

TITLE	PAGE
<b>I. Safety Information</b> .....	1
Environmental Conditions.....	1
Explanation of Symbols.....	1
<b>II. Specification</b> .....	2
General Specification.....	2
Electrical Specification.....	2
<b>III. Instrument Familiarization</b> .....	3
Symbol Definition.....	3
Part and Position.....	4
<b>IV. Measuring Instruction</b> .....	5
4.1 AC Current Measurement.....	5
4.2 AC Voltage Measurement.....	6
4.3 DC Voltage Measurement.....	7
4.4 Resistance Measurement.....	8
4.5 Continuity Test.....	9
4.6 Frequency Measurement from the Terminals.....	10
4.7 Frequency Measurement with the clamp.....	11
4.8 Button Operation.....	12
<b>V. Battery Changing</b> .....	13
<b>VI. Maintenance</b> .....	13

## I. **Safety Information – Read first**

- Read the user manual before use and follow all safety informations.
- Use the meter only as specified in this user manual. Otherwise meter protection may be impaired.
- Never use this meter on a circuit with voltages greater than 750Vrms @ 50/60 Hz.
- Do not operate the meter if the body or tests leads look damaged.
- Check the function selector range switch and make sure it is at the correct position before each measurement.
- Do not perform resistance and continuity test on a live circuit.
- Exercise extreme caution when measuring live systems with voltage greater than 60V DC or 30V AC.
- Use extreme care when working around bus bars and bare conductors.
- Do not use the meter in over range/overload conditions (OL).
- Change the battery when the  symbol appears to avoid erroneous readings.

### **Environmental Conditions:**

Altitude up to 2000 meters.



Operating temperature: 0°C ~ 40°C, <80% RH, non-condensing

Storage temperature: -10°C ~ 60°C, <70% RH, battery removed

Pollution Degree: 2

Installation Categories III (600V), II (1000V)

### **Explanation of Symbols:**

-  Attention! Refer to operation Instructions.
-  Dangerous voltage may be present at terminals.
-  This instrument has double insulation.

When servicing, use only specified replacement parts.

**Approvals:**  EN61010 600V CAT III 1000V CAT II

## II. Specification

### General Specification:

**Digital Display:** 3 3/4 digits LCD display with maximum reading 3999

**Analog Display:** Fast 42 segment analog bar graph display

#### Symbol and Scale range:

Automatic display according symbols and range input signal

**Polarity:**  Displayed when negative signal applied to the input

**Over Load:**  is Displayed when input signal exceeds measuring limit in 40A, 400A, resistance and continuity range.

In voltage, current and frequency range, this symbol will not be shown even the read reach the measuring limit. The measuring limit of these ranges are :

ACV : 750V                      DCV : 1000V

ACA : 1000A                    Hz : 10KHz

**Sample Rate:** 2 times/sec for digital data; 20 times/sec for analog bar

#### Low Battery Indication:

 displayed when the battery is below the required voltage

**Power Source:** 9V, NEDA1604 or 6F22 or 006P

**Battery Life:** 120 hrs typical (Alkaline)

#### Auto Power Off:

The meter will power itself OFF if there is no push button or rotary switch operation for 30 minutes.

To deactivate this function, press the "MAX MIN" button and keep it pressed down, then power up the probe.

**Clamp opening size:** 40mm

**Dimension (L x W x H) :** 242 x 66 x 36 mm, 9.53 x 2.60 x 1.42 inch

**Weight:** 400g, 14.10 OZ (battery included)

**Accessory:** Instruction Manual, Carrying Case, Test lead, 9V Battery

### Electrical Specification:

The accuracy specification is defined as  $\pm( \dots\% \text{reading} + \dots \text{count} )$  At  $23 \pm 5^\circ\text{C}$ ,  $\leq 80\% \text{RH}$

True RMS for ACV and ACA accuracy are specified from 5% to 100% of range, accuracy add  $\pm(1\% \text{rdg})$ , Crest Factor  $1.4 < \text{CF} < 3$  at full scale &  $\text{CF} < 6$  at half scale.

#### ACA ( 400A/1000A Autorange)

Range	Resolution	Accuracy	Overload Protection
40A	0.01A	$\pm ( 1.9\% \text{rdg} + 5 \text{dgts} )$ 50 ~ 500Hz	800Arms
400A	0.1A		1200Arms
1000A	1A		

### ACV (Autorange)

Range	Resolution	Accuracy	Input Impedance	Overload Protection
400V	0.1V	$\pm(1.2\%rdg + 5dpts)$	10M $\Omega$	1200Vpp
750V	1V			

### DCV (Autorange)

Range	Resolution	Accuracy	Input Impedance	Overload Protection
400V	0.1V	$\pm(0.75\%rdg + 2dpts)$	10M $\Omega$	1200Vpp
1000V	1V			

### Ohm (Resistance) (Autorange)

Range	Resolution	Accuracy	Overload Protection
400 $\Omega$	0.1 $\Omega$	$\pm(1\%rdg + 3dpts)$	600Vrms
4000 $\Omega$	1 $\Omega$		

### ➔ (Diode)

Range	Active Region	Overload Protection
➔	0.6mA	600Vrms

### Continuity (•••)

Range	Active Region	Overload Protection
•••	<100 $\Omega$	600Vrms

### Frequency (Hz) (Autorange)

Function	Range	Resolution	Sensitivity	Accuracy
A-Hz	4k	1Hz	2Arms	(20~10KHz)
	10k	10Hz	5Arms	$\pm(0.1\%rdg + 1dpts)$
V-Hz	4K	1Hz	5Vrms	(10~10KHz)
	10K	10Hz	10Vrms	$\pm(0.1\%rdg + 1dpts)$

## III. Instrument Familiarization:

### Symbol Definition:

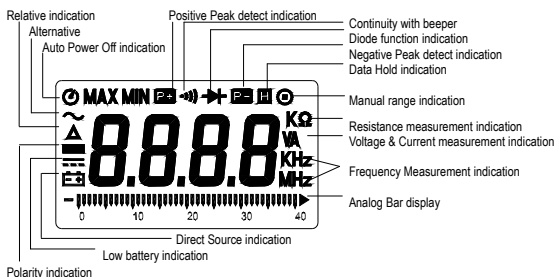

## Part and Position :

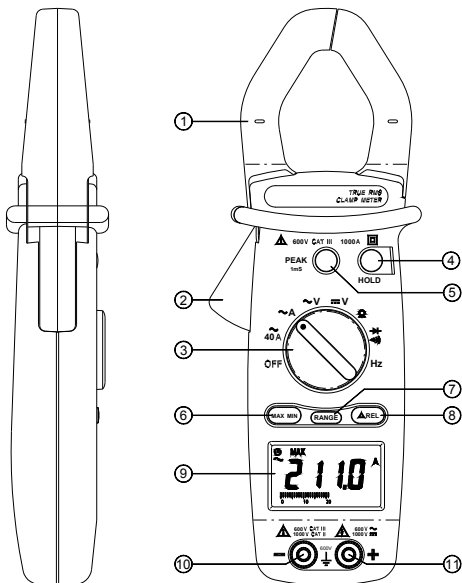

- |                         |                          |
|-------------------------|--------------------------|
| ① Current Sensing Clamp | ② Clamp opening handle   |
| ③ Function select dial  | ④ Hold Button            |
| ⑤ Peak Hold Button      | ⑥ Maximum Minimum Button |
| ⑦ Range button          | ⑧ Relative Button        |
| ⑨ LCD Display           | ⑩ "COM" Terminal         |
| ⑪ "+" test Terminal     |                          |

## IV. Measuring Instruction:

### 4.1 AC Current Measurement:

Switch the main function selector to  $\sim A$  range.

Open the clamp by pressing the jaw-opening handle and insert the cable to be measured into the jaw.

Close the clamp and get the reading from the LCD panel.

#### Note:

Before this measurement, disconnect the test lead with the meter for safety.

In some occasion that the reading is hard to read, push the HOLD button and read the result later.



**CORRECT**

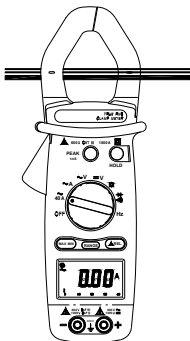
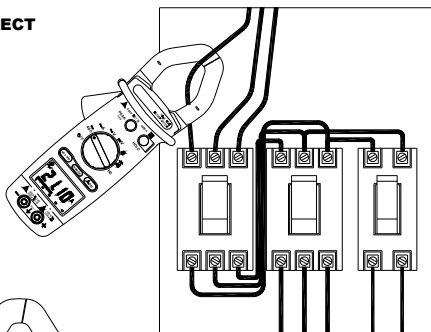

**INCORRECT**

( 2 wires inside )

#### 4.2 ACV measurement:

Switch the main function selector to  $\sim V$  range.

Connect red test lead to “+” terminal and black one to the “COM” terminal.

Measure the voltage by touch the test lead tips to the test circuit where the value of voltage is needed.

Read the result from the LCD panel.

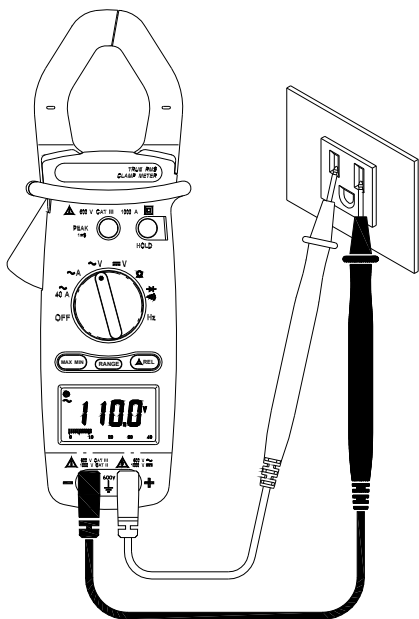

#### 4.3 DCV measurement:

Switch the main function selector to  $V_{\text{DC}}$  range.

Connect red test lead to “+” terminal and black one to the “COM” terminal.

Measure the voltage by touch the test lead tips to the test circuit where the value of voltage is needed.

Read the result from the LCD panel.

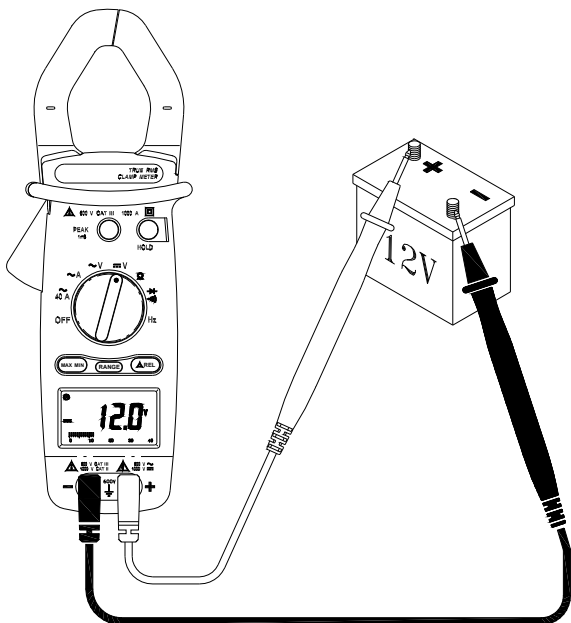

#### 4.4 Resistance measurement:

Switch the main function to “  $\Omega$  ” range, check the power line is disconnected from the system .

Connect red test lead to “+” terminal and black one to the “ COM ” terminal.

Connect tips of the test leads to the points where the value of the resistance is needed.

Read the result from the LCD panel.

#### **Note:**

When take resistance value from a circuit system, make sure the power is cut off and all capacitors need to be discharged.

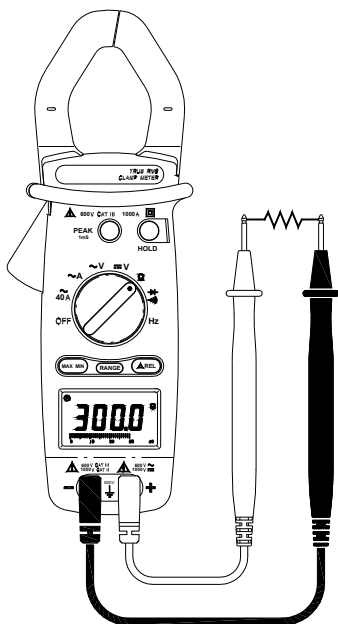

#### 4.5 Continuity Test:

Switch the main function to "  " range, check the power line is disconnected from the system.

Connect red test lead to "+" terminal and black one to the " COM " terminal.

Connect tips of the test leads to the points where the conduction condition needed.

If the resistance is under  $100\Omega$ , the beeper will sound continuously.

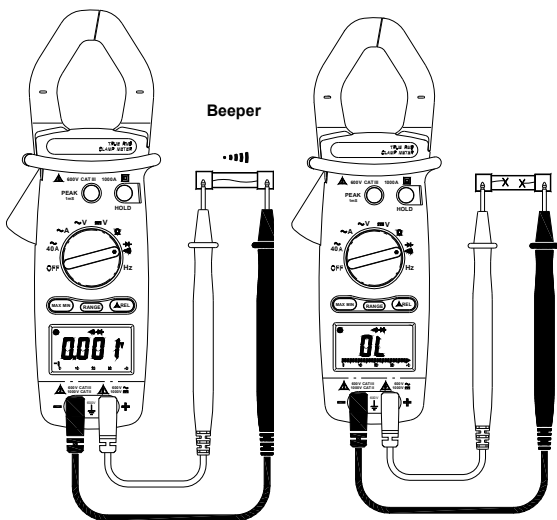

➤ **Short circuit**

➤ **Open circuit**

#### 4.6 Frequency measurement from the terminals:

Switch the main function to “ Hz ” range.

Connect red test lead to “+” terminal and black one to the “ COM ” terminal.

Connect tip of the test leads to the points where the frequency of the voltage signal is needed.

Read the Result from the LCD panel.

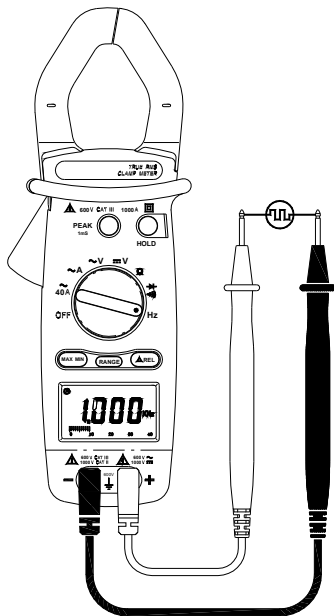

#### 4.7 Frequency measurement with the clamp:

Switch the main function selector to “ Hz ” range.

Open the clamp by pressing the clamp-opening handle and insert the cable to be measured into the clamp.

Close the clamp and get the reading from the LCD panel.

**Note:**

When doing frequency measurement, user should either use the terminal signal or clamp signal but not both. If both sources are applied an error reading will occur.

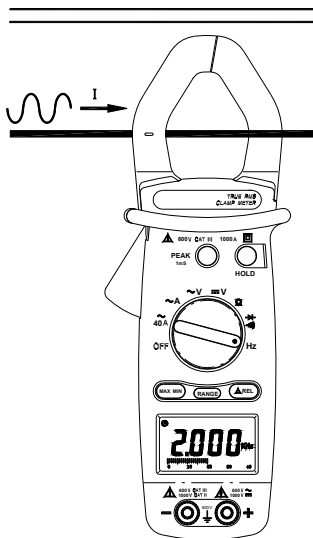

## 4.8 Button Operation:

### ■ Data Hold Function:

At any time, the user can hold the present reading by press the "Hold" button and release the held data by press it again.

### ■ Peak Hold Function:

This meter is built with 1ms peak hold function at ACA, ACV and DCV ranges.

Before the user wants to perform a peak hold operation, he must finish calibration process at first.

To invoke the calibration operation, the user must press and hold the peak button for 2 seconds. After that "CAL" will display on the LCD and the offset will be calculated and kept in the meter.

After the calibration the user can choose P+ or P- by press peak hold button to keep the peak reading. Press the peak button for 2 seconds will return the meter back to normal operation.

Once the function range is changed, the meter will need another calibration for peak measurement.

### ■ MAX/MIN Function:

Press the "MAX/MIN" button once will set the meter to MAX mode.

Press it once again will set the meter to MIN mode.

Press it once again and meter will display the present reading and still keep track of the MAX and MIN change. This mode will also indicated by blinking "MAX MIN" symbol.

Press the "MAX/MIN" button for more than 2 seconds will set the meter back to normal operation.

### ■ REL Function:

Press the "REL" button will change the zero to the present reading and the relative value will show on the LCD.

Press it once again and meter will display the relative zero point. This mode will also indicated by blinking "REL" symbol.

Press the "REL" button for more than 2 seconds will set the meter back to normal operation.

### ■ Range Function:

Press the "RANGE" button to select the manual range mode, and the  annunciator turn on and the meter remains in the same range it was.

To exit the manual range mode and return to auto range mode, press and hold down "RANGE" button for 1 seconds.

## **V. Battery Changing:**

1. When the battery voltage drop below proper operation range the  symbol will appear on the LCD display and the battery need to be changed.
2. Before changing the battery, switch the main dial to "OFF" and disconnect test leads.  
Open the back cover by a screwdriver.  
Replace the old batteries with a new 9V battery.
3. Close the back cover and fasten the screw.

## **VI. Maintenance:**

### **WARNING !**

Before open the meter, disconnect both test lead and never uses the meter before the cover is closed.

### **CAUTION !**

To avoid contamination or static damage, do not touch the circuit board without proper static protection.

### **\* REMARK :**

- If the meter is not going to be used for a long time, take out the battery and do not store the meter in high temperature or high humidity environment.
- When take current measurement, keep the cable at the center of the clamp will get more accurate test result.
- Repairs or servicing not covered in this manual should be performed only by qualified personal.

### **\* CLEANING :**

Periodically wipe the case with a dry cloth. Do not use abrasives or solvents on this instruments.

---

***CENTER***<sup>®</sup>

**CENTER TECHNOLOGY CORP.**

4 / F NO. 415, Jung-Jeng Rd., 238 Shu-Lin, Taipei, Taiwan

TEL : 886-2-26763926

E-Mail : [center@centertek.com](mailto:center@centertek.com)

FAX : 886-2-26763925

[http :// www.centertek.com](http://www.centertek.com)

**211-00**

---