

CENTER[®] 22 AC TRMS CLAMP METER



Instruction Manual

CENTER TECHNOLOGY CORP.

4F, NO. 415, Jung-Jeng Rd., Shu-Lin Dist., New Taipei City 238, Taiwan
E-Mail: center@centertek.com
http://www.centertek.com

GCA000022-12000

Specifications

GENERAL SPECIFICATION:

Display: 4 digits LCD display with maximum reading 4200.

Symbol and Scale range:

Adjust automatically according range and input signal.

Over Load: When the signal larger than the maximum will be shown -OL-

Sample Rate: 2 times/sec for digital data.

Low Power Indication:

When the battery is under the proper operation range, will appear on the LCD display.

Power Source: UM-4 or AAA 1.5V battery x 2

Typical Battery Life: (alkaline battery)

200 hours approx.

Auto Power Off:

If there is no key operation for 15 minutes, the meter will power itself off to save battery consumption.

Disable Auto Power Off:

To disable the function, press the "Hold" button and keep it pressed while powering on the meter. The LCD segments will all light up, the indicator will not be displayed.

Clamp opening size: 23 mm

Dimension / Weight: 149(L)x59(W)x27.5(H)mm / 140g (include battery)

Accessory: Instruction manual, Carrying case, Battery 1.5Vx2

2 Safety Information

- Do not operate the tester if the body of meter look broken.
- Check the main function and make sure it is at the correct position before each measurement.
- Change the battery when the symbol appears to avoid incorrect data.

Environmental Conditions:

- Altitude up to 2000 meters.
- Operating temperature: 0°C ~ 40°C, <80% RH, non-condensing
- Storage temperature: -10°C ~ 60°C, <70% RH, battery removed
- Pollution Degree: 2
- Installation Categories II

Explanation of Symbols:

- Attention! Refer to operation instructions.
- Dangerous voltage may be present at terminals.
- This instrument has double insulation.

Approvals: EN61010 600V CAT III

3 Symbol Definition & Button Location

1. Name of Parts & Position:

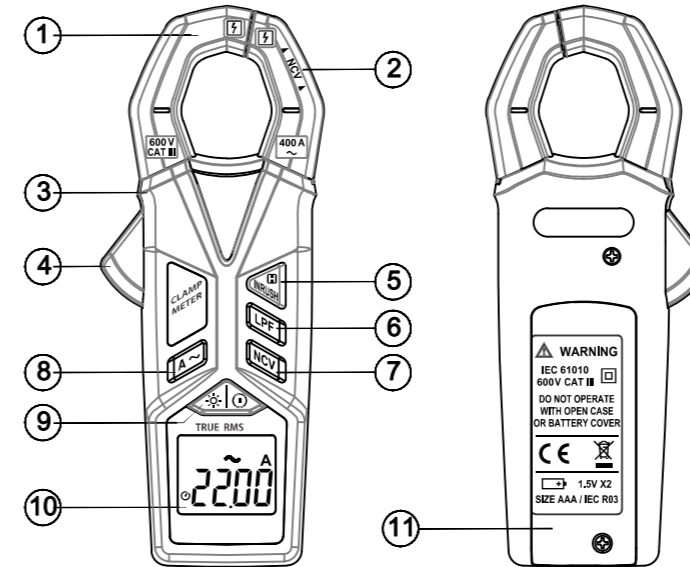

- ① Current sensing clamp
- ② NCV induction area
- ③ Safety protection ring
- ④ Clamp opening handle
- ⑤ Hold/Inrush button
- ⑥ LPF button
- ⑦ NCV button
- ⑧ AC button
- ⑨ Power On/Off/Backlight button
- ⑩ LCD display
- ⑪ Battery compartment cover

3. LCD Display:

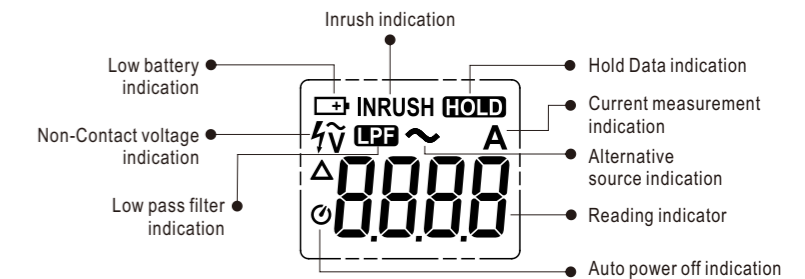

Maintenance

WARNING & CAUTION!

- Before opening the battery door, disconnect both test leads and never use the meter if the battery door is open.
- To avoid contamination or static damage, do not touch the circuit board without proper static protection.

REMARK:

If the meter is not going to be used for a long time, take out the battery and do not store the meter in high temperature or high humidity environment.

When taking current measurement, keep the cable at the center of the clamp to get more accurate test result.

Repairs or servicing not covered in this manual should be performed only by qualified person.

CLEANING:

Periodically wipe the case with a dry cloth and detergent.
Do not use abrasives or solvents on this instrument.

Measuring Instructions

(1) ACA measurement:

Press the "A" button to access the AC Current measurement mode. The "A" symbol will appear on display.

Open the clamp by pressing the jaw-opening handle and insert the cable to be measured into the jaw.

Close the clamp and get the reading from the LCD panel.

Note:

In some occasion that the reading is hard to read, push the button and read the result later.

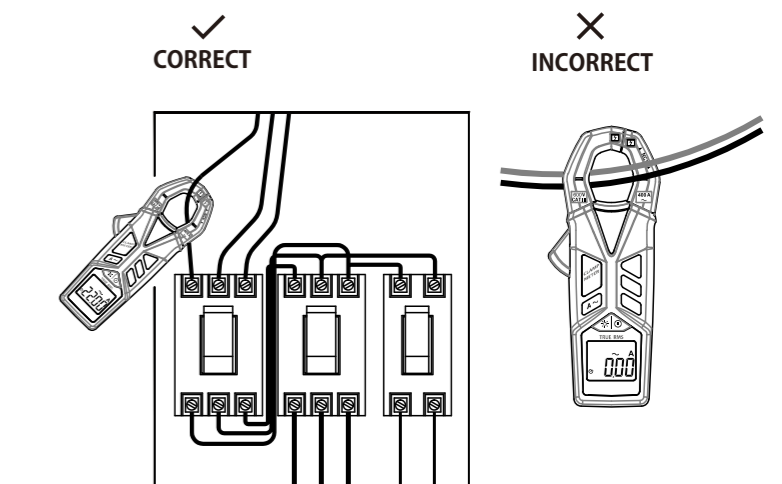

5 ELECTRICAL SPECIFICATION:

The accuracy specification is defined as $\pm(\dots\% \text{reading} + \dots \text{count})$ at $23 \pm 5^\circ\text{C}$, $\leq 80\% \text{RH}$

ACA (Aurorange)

Range	Resolution	Accuracy		Overload Protection
		50Hz~60Hz	45Hz~400Hz	
40A	0.01A	$\pm 2.0\% + 5\text{dpts}$	$\pm 3.8\% + 8\text{dpts}$	420Arms
400A	0.1A			

Low Pass Filter(LPF) (Aurorange)

Range	Resolution	Accuracy	Overload Protection
		50Hz ~ 60Hz	
40A	0.01A	$\pm 3.5\% + 8\text{dpts}$	420Arms
400A	0.1A		

Note: Cut-off frequency(-3dB):160Hz

Inrush Current

Range	Resolution	Accuracy	Overload Protection
400A	0.1A	$\pm 3.5\% + 8\text{dpts}$	420Arms

Note:

Integration time: 100ms
Trigger current(threshold): 5A

NCV Sense

Volt sense indication bar with beep should be on at 100VAC@ 1inch(2.54cm)

6 Button Instructions

Hold / Inrush Function:

Press "" button to freeze the data shown on the LCD screen. Press it again to exit Data-Hold mode.

If you press and hold the button for 2 seconds, to access inrush current mode, the LCD display will show "INRUSH", "----" until the motor starting up and being detected (5A above). The detection will be done only on time and the output reading will be hold.

To exit inrush current mode, press and hold the button for 2 seconds or "" button.

Power On/Off / Back-Light Function:

Press "" button to turn on the meter. Press and hold the button for 2 seconds to turn off.

Press "" button to turn on the LCD back-light. This makes it easier to read in dark environment. Press it again to turn off back-light. The back-light will be automatically turned off after 10 seconds to save battery power.

NCV Function:

Press "" button to enter NCV (non-contact voltage detector) function. "" symbol will appear on the display. To exit NCV mode, press "" button.

LPF(Low Pass Filter) Function:

Press "" button. "" symbol will appear on the display. Press it again, or press "" button to exit the LPF mode.

Note: This meter is built with LPF function at ACA ranges.

(2) Inrush Current Mode:

Press and hold the "" button for 2 seconds to access the Inrush current mode. The LCD display will show "INRUSH", "----" until the motor starting up for a 100ms period and being detected (5A above). The detection will be done only on time and the output reading will be hold.

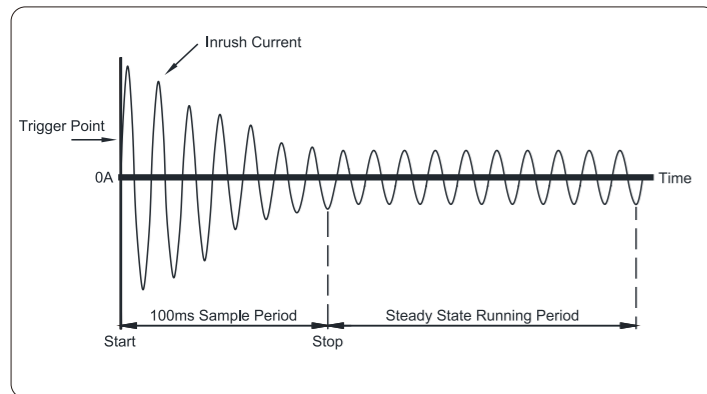
**(3) Low Pass Filter:**

The Low-Pass Filter is a filter that passes signals with a frequency lower than a certain cutoff frequency and attenuates signals with frequencies higher than the cutoff frequency.
The Low-Pass Filter offers a cut-off frequency of 160Hz (approx.)

(4) Non-Contact Voltage (NCV):**▲ DANGER!**

The LCD and beeper may not be displayed due to installation condition of electrical circuit or equipment. Never touch the circuit under test to avoid possible danger even if the LCD and beeper for NCV is not displayed. Check the functionality of LCD and beeper on a well-known power supply prior to measurement. When the LCD and beeper doesn't indicate, do not make measurement.

NCV indication is affected by external voltage, and how the meter is held or placed.

Press the "" button to access the NCV measurement mode.

Annunciate and "EF" will appear on the display.

When no or less electric field is detected, the LCD shows "EF". If the detector senses electric field, the strength will be showed on LCD by "—" with beep.

Level 1(weak) is "—" and the level 4(strong) is "----".

The beeper frequency depends on the strength of electric field also.

Place the edge of the jaw labeled "▲ NCV ▲" near the electric field.

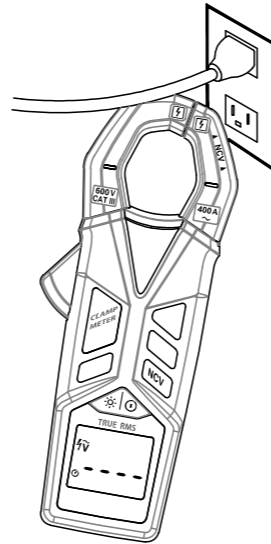
**Replacing Battery**

1. When the battery voltage drops below proper operation range, the symbol  will appear on the LCD and the battery needs to be replaced.
2. Before replacing the battery, power off the meter .
3. Open the battery door by a screwdriver.
Replace the old batteries with two UM-4 or AAA size batteries.
4. Close the battery door and fasten the screw.

