

***CENTER*® 235**

AC Clamp Meter

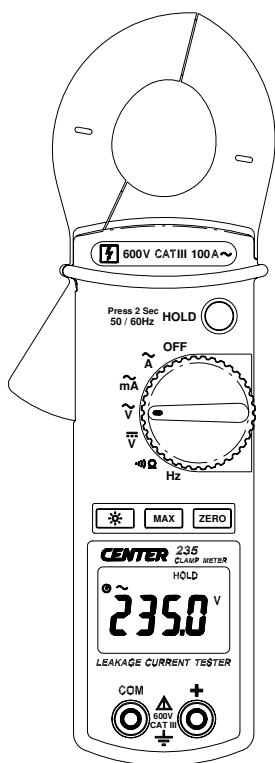

CE

Instruction

Manual

LEAKAGE CURRENT TESTER

CONTENTS

TITLE	PAGE
I. Safety Information	1
Environmental Conditions.....	1
Explanation of Symbols.....	1
II. Specification.....	2
General Specification.....	2
Electrical Specification.....	3
III. Instrument Familiarization.....	4
Symbol Definition.....	4
Instrument Familiarization.....	4
Button Instruction.....	4
IV. Measuring Instruction.....	6
4.1 ACA	

I. Safety Information

Do not operate the unit if the casing or the test Leads are or look damaged.

Check the main function dial to ensure it is set at the correct position before each measurement.

Do not perform resistance and continuity test on a live “powered” system.

Do not apply voltage between the test terminals and test terminal to ground that exceed the maximum limit referred to in this manual.

Exercise extreme caution when measuring live systems with voltage greater than 60V DC or 30V AC.

Keep fingers behind the protection ring when measuring with test leads.

Replace batteries when the  symbol appears to avoid incorrect data.

Environmental Conditions:

Altitude up to 2000 meters.

Operating temperature: 0°C ~ 40°C, <80% RH, non-condensing

Storage temperature: -10°C ~ 60°C, <70% RH, battery removed

Pollution Degree: 2

Explanation of Symbols:

 Attention refer to operation Instructions.

 Dangerous voltage may be present at terminals.

 This instrument has double insulation.

Approvals:  EN61010 600V CAT III

II. Specification

General Specification:

Digital Display:

4 digits LCD display with maximum reading 9999

Over Load:

When the signal input exceeds the maximum limit "OL" will be display.

Sample Rate:

2 times/sec

Low Power Indication:

When the battery is below the proper operation range,  symbol will appear on the LCD display.

Auto Power Off:

The meter will power it self OFF after 10 minutes of inactivity.

Power Source: UM-4 or AAA 1.5V battery x 2.

Battery Life: 45 hr approx. (alkaline battery)

Backlight: LED with 180 sec auto shut down

Clamp opening size: 28mm

Dimension (L x W x H) :

218x64x30mm,

Weight: approx 280g(include battery)

Accessory:

Instruction Manual, Carrying Case, Test lead, Battery 1.5Vx2

Electrical Specification:

(

III. Instrument Familiarization:

Symbol Definition:

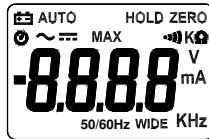

Instrument Familiarization:

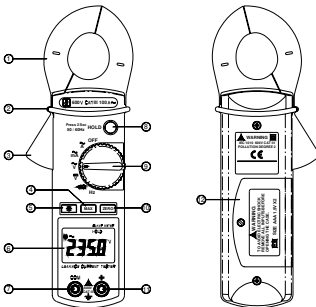

- **Max Hold Button**

Press "**Max**" button to enter the Max mode, "**Max**" Annunciate will appear and the **Max** display. Press the **Max** button again, to exit the **Max** mode.

- **Back Light Function:**

Press the "Back Light" button will turn back light on and Press it once again will turn off.

The meter will turn back light off if there is no push "Back Light" button for 30 seconds.

- **Data Hold &50/60HZ**

To activate the Data Hold feature, press the "**Hold**" button.

To de-activate the Data Hold feature, press the "**Hold**" button again.

To activate the Data Hold feature, press and hold the "**50/60HZ**" button until the symbol displays.

To deactivate the 50/60HZ feature, press and hold the "**50/60HZ**" button for 2 seconds. The meter will return to WIDE mode operation.

Note: This meter is built with 50/60HZ function at ACA, ACmA ranges.

- **How to use frequency selector button**

When high frequencies from such equipment as inverters are presented in the circuit under test. This instrument measures AC current of not only 50HZ or 60HZ of fundamental frequency but also the harmonics

To eliminate the effect of such high frequency noise and measure only the AC current of 50Hz or 60Hz fundamental frequency, a "high-cut" filter is built in this instrument.

When the frequency selector button is pressed "50/60HZ" mark is shown on the display and when the frequency selector button is pressed again, frequency response is switched to wide band with "WIDE" mark shown on the display.

- **Disable Auto power off**

Press and hold "**ZERO**" button and then the power on the meter, the symbol  will disappear.

IV. Measuring Instruction:

4.1 ACA

Fig.2 Measuring out of balance leakage current:

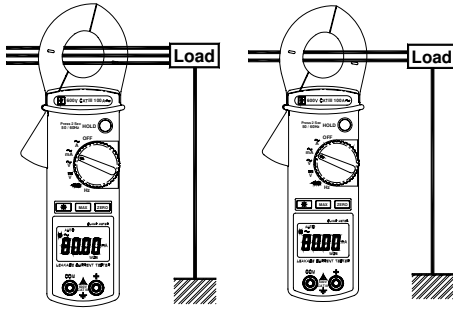

3-Phase 3-Wire system

Single-Phase 2-Wire system

4.2 ACV measurement:

⚠ WARNING!

Maximum Input Voltage is 600V AC/DC. Do not attempt to Take any voltage measurement that may exceed this maximum to avoid Electrical shock hazard and/or damage to this instrument.

Switch the function selector to $V \sim$ range.

Connect red test lead to “+” terminal and black one to the “COM” terminal.

Measure the voltage by touching the test lead tips to the test circuit where the voltage of voltage is needed.

Read the result from the LCD panel.

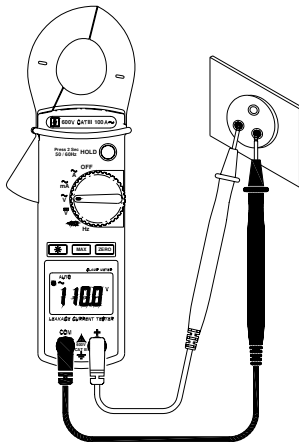

4.3 DCV measurement:

Switch the function selector to **V** $\overline{\text{---}}$ range.

Connect red test lead to “+” terminal and black one to the “COM” terminal.

Measure the voltage by touching the test lead tips to the test circuit where the value of voltage is needed.

Read the result from the LCD panel.

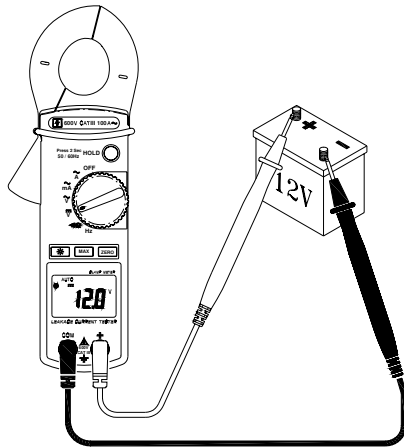

4.4 Resistance measurement:

Switch the function selector to Ω range.

Connect red test lead to “+” terminal and black one to the “ COM ” terminal.

Connect tip of the test leads to the points where the value of the resistance is needed.

Read the Ohm value from the LCD panel.

Note:

When measuring resistance value from a circuit, make sure the power is cut off and all capacitors are discharged.

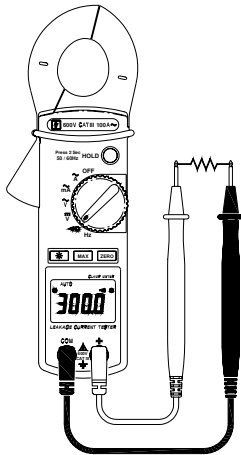

4.5 Continuity Test:

Switch the function selector to  range.

Connect red test lead to “+” terminal and black one to the “ COM ” terminal.

Connect tip of the test leads to the points where continuity is to be tested.

If the resistance is under 35

4.6 Frequency measurement from the terminals:

Switch the main function to “ Hz ” range.

Connect red test lead to “+” terminal and black one to the “ COM ” terminal.

Connect tip of the test leads to the points where the frequency of the voltage signal is needed.

Read the Result from the LCD panel.

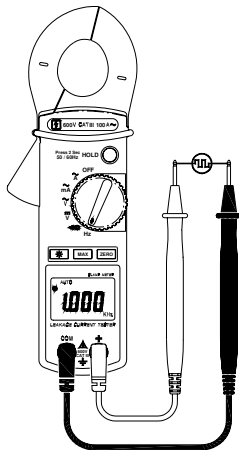

4.7 Frequency measurement with the clamp:

Switch the main function selector to “ Hz ” range.

Open the clamp by pressing the clamp-opening handle and insert the cable to be measured into the clamp.

Close the clamp and get the reading form the LCD panel.

Note:

When doing frequency measurement, user should either use the terminal signal or clamp signal but not both. If both sources are applied an error reading will occur.

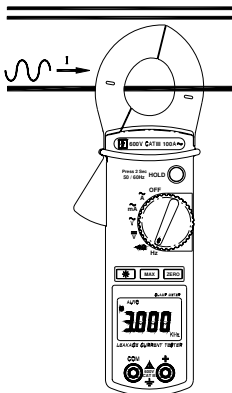

V. Battery Changing:

1. When the battery voltage drops below proper operation range the symbol  will appear on the LCD display and the battery will need to be changed.
2. Before changing the battery, switch the function selector to "OFF" and disconnect test leads.
Open the back cover using a screw driver. Replace the old batteries with two UM-4 or AAA size batteries.
3. Close the back cover and fasten the screw.

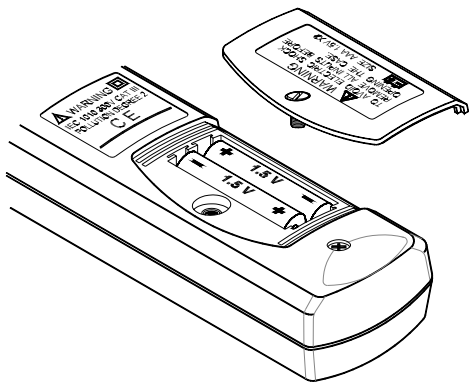

VI. Maintenance:

CAUTION

To avoid contamination or static damage, do not touch the circuit board without proper static protection.

REMARK

- * Remove the batteries, if the meter is not used for extended periods of time. Do not store the meter in a high temperature/humidity environment.
- * When measuring current, keep the cable at the center of the clamp to get more accurate readings.

CLEANING

Periodically wipe the case with a dry cloth and without detergent. Do not use abrasives or solvents on this instrument.

CENTER[®] CENTER TECHNOLOGY CORP.

4 / F NO. 415, Jung-Jeng Rd., 238 Shu-Lin, Taipei, Taiwan

TEL : 886-2-26763926 E-Mail : center@centertek.com

FAX : 886-2-26763925 http : // www.centertek.com

235-00
