

CENTER[®] 27

**Instruction
Manual**



CE

AC TRMS CLAMP METER

TABLE OF CONTENTS

1. SAFETY INFORMATION	1
2. GENERAL SPECIFICATION	1
3. ELECTRICAL SPECIFICATION	2
3-1 Direct Voltage.....	2
3-2 Alternating Voltage	2
3-3 Alternating Current	2
3-4 Resistance(Ω)	3
3-5 Continuity(\cdot))	3
4. DESCRIPTION OF THE INSTRUMENT	3
4-1 Description of the display	3
4-2 Description of front and rear	4
5. BUTTON INSTRUCTION	5
5-1 Hold Function	5
5-2 Min/Max Function	5
5-3 AC/DC Voltage & \cdot) / Ω Function	5
6. MEASURING INSTRUCTION	5
6-1 AC Voltage Measurement	5
6-2 DC Voltage Measurement	6
6-3 AC Current Measurement	6
6-4 Resistance Measurement	7
6-5 Continuity Measurement	7
7. BATTERY CHANGING	8
8. MAINTENANCE	8

1. SAFETY INFORMATION

Do not operate the tester if the body of meter or the test lead look broken.

Check the main function dial and make sure it is at the correct position before each measurement.

Do not perform resistance and continuity test on a live power system. Do not apply voltage between the test terminals and test terminal to ground that exceed the maximum limit record in this manual.

Keep the fingers after the protection ring when measuring through the test lead.

Change the battery when the  symbol appears to avoid incorrect data.

Environmental Conditions

Operation Temperature: 0°C to 40°C(32°F to 104°F); < 80 % RH

Storage Temperature: -10°C to 60°C(14°F to 140°F); < 70 % RH

Explanation Symbols



Attention refer to operation Instructions.



Dangerous voltage may be present at terminals.



This instrument has double insulation.

Approvals:  EN61010 600V CAT III

2. GENERAL SPECIFICATION

Digital Display:

4 digital liquid crystal(LCD), Maximum reading 6000.

Polarity:

When a negative signal is applied, the  signal appears.

Low Battery Indication:

When the battery is under the proper operation range,  will appear on the LCD display.

Sample Rate:

2 times/sec .

Power Source:

CR2032 (3VDC) X 1

Typical battery Life: 24 hours (without buzzer)

Auto Power Off:

If there is no key or dial operation for 10 minutes, the meter will power itself off to save battery consumption. This function can be disabled by press and hold the "HOLD" button then power the unit on.

Over Load:

When the signal larger than the maximum will be show **-OL-**.

Maximum jaw opening:

∅ 40 mm

Dimensions:

207 x 66 x 26 mm

Weight:

Approx. 153g (with battery)

Accessories:

Carrying case, Battery, Test Lead & Instruction Manual.

3. ELECTRICAL SPECIFICATION

The accuracy specification is defined as $\pm[\dots\% \text{reading} + \dots \text{count}]$ at $23 \pm 5^\circ\text{C}$, $\leq 80\% \text{RH}$. True RMS for VAC and AAC accuracy are specified from 5% to 100% of range, crest factor $CF < 1.6$ at full scale & $CF < 3.2$ at half scale.

3-1 Direct Voltage ()

Range	Resolution	Accuracy	Overload Protection
6V	0.001V	1% \pm 2dgts	600Vrms
60V	0.01V		
600V	0.01V		

Input impedance: 10 M Ω

3-2 Alternating Voltage ()

Range	Resolution	Accuracy	Overload Protection
6V	0.001V	1.2% \pm 5dgts (50~500Hz)	600Vrms
60V	0.01V		
600V	0.01V		

LCD displays 0 when the reading < 20counts (6V range only)

Input impedance: 10 M Ω

3-3 Alternating Current ()

Range	Resolution	Accuracy	Overload Protection
600A	0.1A	1.9% \pm 5dgts(50~60Hz)	1000Arms
1000A	1A	2.5% \pm 5dgts(45~500Hz)	

3-4 Resistance (Ω)

Range	Resolution	Accuracy	Overload Protection
600 Ω	0.1 Ω	1% \pm 2dgts	600Vrms
6K Ω	0.001K Ω		
60K Ω	0.01K Ω		
600K Ω	0.1K Ω		

3-5 Continuity (\cdot)

Range	Resolution	Accuracy	Overload Protection
600 Ω	0.1 Ω	1% \pm 2dgts	600Vrms
\cdot)	Ohm function Buzzer<100 Ω		

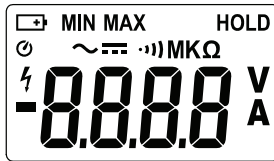
4. DESCRIPTION OF THE INSTRUMENT**4-1 Description Of The Display**

	Auto Power Off Indication
	Polarity Indication
	Low Battery Indication
	Alternative Source Indication
	Direct Source Indication
A/V	Current / Voltage Measurement Indication
	Danger Voltage Indication
HOLD	Data Hold Indication
MIN MAX	Min/Max Indication
\cdot)	Continuity Test Indication
M / K	Measurement Unit
Ω	Resistance measurement indication

4-2 Description Of Front And Rear

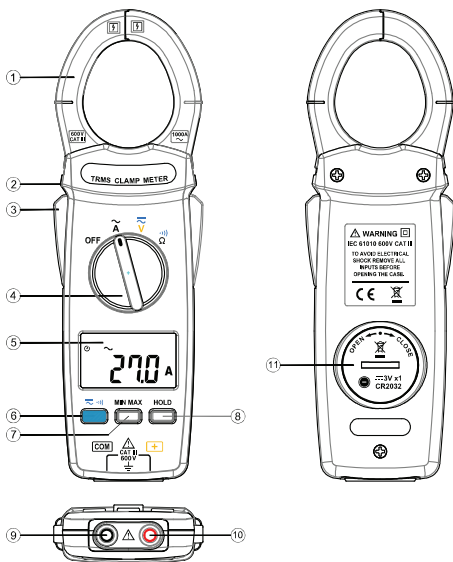

- ① Current Sensing Clamp
- ② Safety Protection Ring
- ③ Clamp Opening Handle
- ④ Function Select Dial
- ⑤ LCD Display
- ⑥ AC/DC Voltage & Ω Select Button
- ⑦ Min/Max Button
- ⑧ Data Hold Button
- ⑨ COM Input Terminal
- ⑩ Positive Input Terminal
- ⑪ Battery Cabinet

5. BUTTON INSTRUCTION

5-1 HOLD Function

It is possible to freeze the value displayed by pressing on the "HOLD" button. To deactivate this function, press the "HOLD" button a second time.

5-2 MIN/MAX Function

Press the **MIN/MAX** button to enter the Min/Max mode. Press the **MIN/MAX** button, to read Max, Min, and current reading in sequence. Press the **MIN/MAX** button for 2 seconds, to exit the Min/Max mode.

5-3 AC/DC Voltage Select and Ω/Ω Select Button

Press  button to select function.

To select function AC or DC in Voltage range.

To select continuity or Resistance in Ω range.

6. MEASURING INSTRUCTION

6-1 AC Voltage Measurement :

Switch the main function selector to  range.

Connect red test lead to "+" terminal and black one to the "COM" terminal.

Measure the voltage by touch the test lead tips to the test circuit where the value of voltage is needed.

Read the result from the LCD panel.

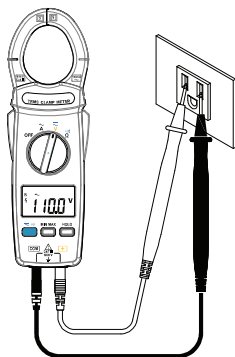

6-2 DC Voltage Measurement :

Switch the main function selector to \overline{V} range.

Connect red test lead to “+” terminal and black one to the “COM” terminal.

Measure the voltage by touch the test lead tips to the test circuit where the value of voltage is needed.

Read the result from the LCD panel.

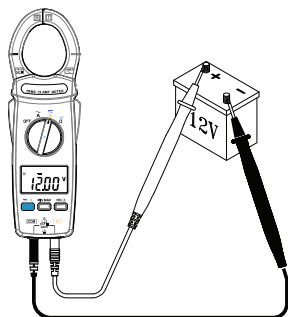
**Note:**

When the reading is exceeding 30V in ACV or DCV, the ⚡ symbol will be displayed on.

6-3 AC Current Measurement :

Switch the main function selector to \tilde{A} range.

Open the clamp by pressing the jaw-opening handle and insert the cable to be measured into the jaw.

Close the clamp and get the reading from the LCD panel.

Note :

Before this measurement, disconnect the test lead with the meter for safety.

In some occasion that the reading is hard to read, push the HOLD button and read the result later.

✗ INCORRECT

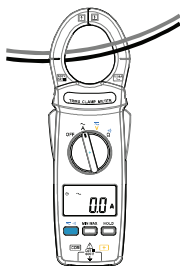

✓ CORRECT

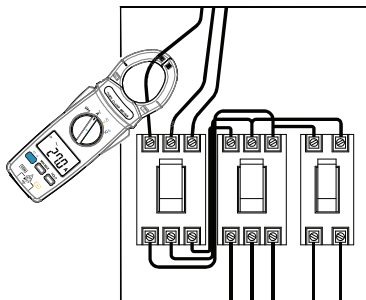

6-4 Resistance Measurement

Switch the main function to Ω range.

Connect red test lead to “+” terminal and black one to the “COM” terminal.

Connect tip of the test leads to the points where the value of the resistance is needed.

Read the result from the LCD panel.

Note :

When take resistance value from a circuit system, make sure the power is cut off and all capacitors need to be discharged.

**6-5 Continuity Test With Buzzer :**

Switch the main function to Ω range.

Connect red test lead to “+” terminal and black one to the “COM” terminal.

Connect tip of the test leads to the points where the conduction condition needed.

If the resistance is under 100Ω , the beeper will sound continuously.



Short circuit

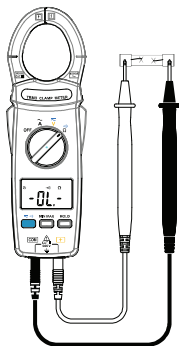

Open circuit

7. BATTERY CHANGING

- (1) When the battery voltage drop below proper operation range the  symbol will appear on the LCD display and the battery needs to be changed.
- (2) Before changing the battery, switch the main dial to "OFF" and disconnect test leads.
- (3) Open the back cover by an appropriate tool.
- (4) Replace the old battery with new 3V (CR2032) battery.
- (5) Close the Battery cover .

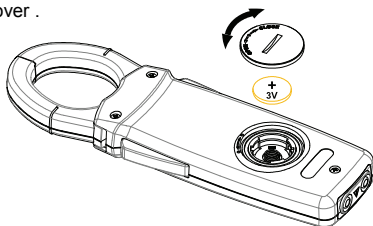

8. MAINTENANCE

WARNING!

Before open the meter, disconnect both test lead and never uses the meter before the cover is closed.

CAUTION!

To avoid contamination or static damage, do not touch the circuit board without proper static protection.

8-1 REMARK:

- (1) If the meter is not going to be used for a long time, take out the battery and do not store the meter in high temperature or high humidity environment.
- (2) When take current measurement, keep the cable at the center of the clamp will get more accurate test result.
- (3) Repairs or servicing not covered in this manual should be performed only by qualified personal.

8-2 CLEANING:

Periodically wipe the case with a dry cloth.

Do not use abrasives or solvents on these instruments.

CENTER[®] CENTER TECHNOLOGY CORP.

4F, NO.415, Jung-Jeng Rd., Shu-Lin Dist.,

New Taipei City 238, Taiwan

TEL : 886-2-26763926

E-Mail : center@centertek.com

FAX : 886-2-26763925

http : // www.centertek.com

GCA00027-02000
