

COMET SYSTEM

www.cometsystem.com

Web Sensor P8552 with binary inputs

PoE Web Sensor P8652 with binary inputs

PoE Web Sensor P8653 with flood detector and
binary inputs

USER GUIDE

© **Copyright: COMET SYSTEM, s.r.o.**

Is prohibited to copy and make any changes in this manual, without explicit agreement of company COMET SYSTEM, s.r.o. All rights reserved.

COMET SYSTEM, s.r.o. makes constant development and improvement of their products. Manufacturer reserves the right to make technical changes to the device without previous notice. Misprints reserved.

Manufacturer is not responsible for damages caused by using the device in conflict with this manual. To damages caused by using the device in conflict with this manual may not be provide free repairs during the warranty period.

Contact the manufacturer of this device:

COMET SYSTEM, s.r.o.
 Bezrucova 2901
 756 61 Roznov pod Radhostem
 Czech Republic
www.cometsystem.com

Revision history

This manual describes devices with latest firmware version according to the table below. Older version of manual can be obtained from a technical support.

Document version	Date of issue	Firmware version	Note
IE-SNC-P8x52-01	2014-09-25	4-5-6-0	Initial revision of manual.
IE-SNC-P8x52-02	2015-02-18	4-5-7-0	
IE-SNC-P8x52-03	2015-09-24	4-5-8-0	
IE-SNC-P8x52-04	2017-10-26	4-5-8-1	
IE-SNC-P8x52-05	2019-05-03	4-5-8-1	Change in operating terms for P8552
IE-SNC-P8x52-06	2022-07-01	4-5-8-1	Change of case material
IE-SNC-P8x52-07	2023-03-06	4-5-8-2	Added new device P8653, typos correction



Distributor in Australia
Pacific Sensor Technologies Pty Ltd
 Unit 4, 3 Neutron Place Rowville, VIC 3178 Australia
 1300 662 720 | sales@pacificsensortech.com.au
www.pacificsensortech.com.au

Table of contents

Introduction.....	4
General safety rules	4
Device description and important notices.....	5
Getting started.....	7
What is needed for operation	7
Mounting the device.....	7
Device settings	9
Checking functions.....	10
Device setup	11
Setup using web interface.....	11
Setup using TSensor software	20
Factory defaults.....	21
Communication protocols	24
Website.....	24
SMTP – sending e-mails.....	24
SNMP	25
Modbus TCP.....	26
SOAP.....	28
Syslog.....	30
SNTP.....	30
Software development kit.....	30
Troubleshooting.....	31
I forgot the device IP address.....	31
I cannot connect to the device	31
Error or n/a is displayed instead the measured value	32
Binary inputs not show the correct values.....	32
I forgot the password for setup.....	32
Factory defaults.....	33
Technical specifications	34
Dimensions.....	34
Basic parameters	34
Operating terms	37
End of operation	37
Technical support and service	37
Preventive maintenance.....	37
Optional accessories.....	38

Introduction

This chapter provides basic information about device. Before starting, please read this manual carefully.

Web Sensors P8552, P8652 and P8653 are designed to measure temperature or relative humidity up to two external probes. This allows to measure values from two different places by one device. Temperature can be displayed in °C or °F. Relative humidity have unit %RH. Devices are equipped by three binary inputs. P8552 and P8652 are quipped by three binary inputs to get state from dry contacts or binary sensors with voltage output. Type of the binary input is selectable in device setup. P8653 have dedicated first binary input for connection of flood detector LD-81. This detector is part of the shipment. Other two binary inputs can be used to connection of dry contacts or binary sensors with voltage output. Type of these two binary inputs is selectable at device setup.

Communication with the device is realized via Ethernet network. Devices P8652 and P8653 can be powered from external power supply adapter or by using power over Ethernet – PoE. Web Sensor P8552 supports powering from adapter only.

General safety rules

The following summary is used to reduce the risk of injury or damage the device. To prevent injury, please follow instructions in this manual.



The device can be services only by a qualified person. The device contains no serviceable parts inside.

Don't use the device if it doesn't work correctly. If you think that the device is not working correctly, let check it by qualified service person.

Don't disassemble the device. It's forbidden to use the device without the cover. Inside the device can be a dangerous voltage and may be risk of electric shock.

Use only the appropriate power supply adapter according to manufacturer specifications and approved according to relevant standards. Make sure, that the adapter does not have damaged cables or covers.

Connect the device only to network parts approved according to relevant standards. Where power over Ethernet is used, the network infrastructure must be compatible with IEEE 802.3af standard.

Connect and disconnect the device properly. Don't connect or disconnect Ethernet cable, binary inputs or probes, if the device is powered.

Do not connect higher voltage to binary inputs than is allowed.

The device may be installed only in prescribed areas. Never expose the device to higher or lower temperatures than is allowed. The device has not improved resistance to moisture. Protect it from dripping or splashing water and do not use at areas with condensation.

Don't use device in potentially explosive environments.

Don't stress the device mechanically.

Device description and important notices

This chapter contains information about basic features. Also, there are important notices concerning to functional safety.

Values from the device can be read using an Ethernet connection. The following formats are supported:

- Web pages
- Current values in XML and JSON format
- Modbus TCP protocol
- SNMPv1 protocol
- SOAP protocol

The device can also be used to check measured values and if the limit is exceeded, device sends warning messages. Possible ways to sending warning messages:

- Sending e-mails up to 3 e-mail addresses
- Sending SNMP traps up to 3 configurable IP addresses
- Displaying the alarm status on web page
- Sending messages to Syslog server

The device setup can be made by the TSensor software or by web interface. TSensor software can be free downloaded from the manufacturer's website. Latest firmware can be obtained from the technical support. Do not upload to your device firmware which is not designed for it. Unsupported firmware can damage your device.

If you want to use PoE, you must use PoE switch compatible with IEEE 802.3af standard.



Reliability of warning messages delivering (e-mail, trap, syslog), depends on actual availability of necessary network services. The device should not be used for critical applications, where malfunction could cause to injury or loss of human life. For highly reliable systems, redundancy is essential. Please see standard IEC 61508 and IEC 61511 for more information.



Never connect the device directly to the Internet. If it is necessary connect the device to the Internet, properly configured firewall must be used. For secured remote access use VPN connection.

Getting started

Here you can find information necessary to put newly purchased equipment to operation. This procedure is only informative.

What is needed for operation

To install the device, you need to the following equipment. Before installation check if it's available.

- Web Sensor P8552, Web Sensor P8652 or Web Sensor P8653
- power supply adapter 5V/250mA or switch with PoE support. Before using the device is necessary to decide which way of powering will be used. PoE is supported by Web Sensor P8652 and Web Sensor P8653.
- RJ45 LAN connection with appropriate cable
- free IPv4 address in your network
- up to 2 two temperatures probes type DSTR162/C, DSTGL40/C, DSTG8/C or relative humidity probe DSRH, DSRH+, DSHR/C
- sensors with two state output to connection into binary inputs of Web Sensor (dry contacts or voltage contacts)
- for P8653 device flood detector LD-81 which is part of shipment

Mounting the device

- check if the equipment from previous chapter is available
- install the latest version of TSensor software. This software will help you find device on network and to change IP address of the device. Device configuration is made using web interface. TSensor software can be free downloaded from the manufacturer's website. Due to reducing impact to environment is CD not part of shipment.
- contact your network administrator to obtain following information for the connection to the network:

IPv4 address:	_____.	_____.	_____.	_____.
Gateway:	_____.	_____.	_____.	_____.
DNS server IP:	_____.	_____.	_____.	_____.
Netmask:	_____.	_____.	_____.	_____.

- check if there is no IP address conflict when you connect the device into network for the first time. The device has from factory set the IP address to **192.168.1.213**. This address must be changed according to information from the previous step. When you are installing several new devices, connect them to the network one after another.
- connect temperature and humidity probes to Web Sensor
- connect binary inputs of the device, for device P8653 connect flood detector LD-81 at the first binary input (BIN1)
- connect the Ethernet connector
- if the power over Ethernet (PoE) is not used, connect the power adapter 5V/250mA
- LEDs on LAN connector should blink after connecting the power

Web Sensor connection (power supply adapter, Power over Ethernet):

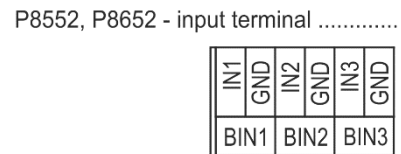
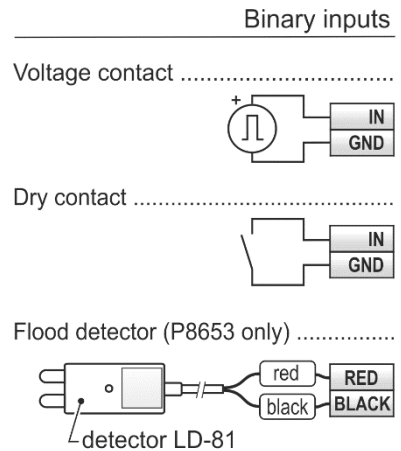
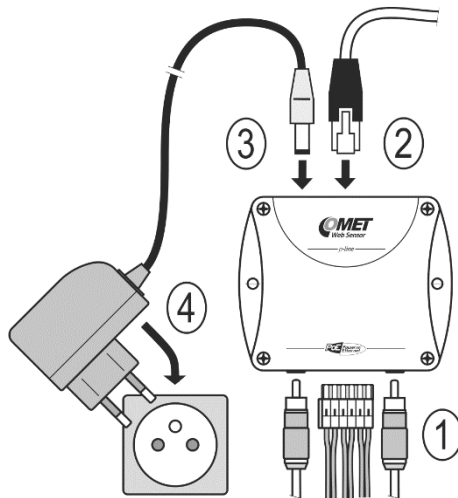

binary input: BIN1 BIN2 BIN3

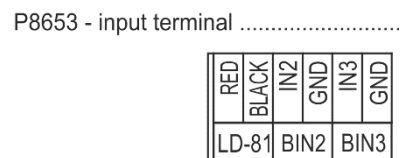

binary input: BIN1 BIN2 BIN3

Binary inputs terminals connection procedure:

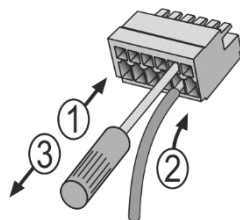

correctly and there will be collisions on the network. If the device detects a collision of IP address, then reboot is performed automatically.

- after changing IP address device is restarted and new IP address is assigned. Restart of the device takes about 10 seconds.
- find the connected probes and change binary input type on webpages of by TSensor, if necessary

Checking functions

The last step is to check measured values on the device website. Enter the device IP address into address bar of the web browser. If the default IP address was not changed, then insert **http://192.168.1.213**.

Displayed web page lists actual measured values. If the web pages are disabled, you can see text **Access denied**. If the measured value exceeds the measurement range or probe is not correctly installed, then is shown **Error** message. If the channel is switched off, the web site displayed **n/a** instead of the value.

Device setup

This chapter describes basic device configuration. There is a description of settings using web interface.

Setup using web interface

Device can be setup using web interface or TSensor software. Web interface can be managed by the web browser. Main page will be shown when you insert device address into address bar of your web browser. There you find actual measured values. Page with history graphs is shown when you click to tile with actual values. Access to device setup is possible via tile **Settings**.

The screenshot shows a web browser window with the address bar containing '192.168.1.213'. The page title is 'Web Sensor' and the URL is 's/n: 14942068'. The time displayed is '15:57:06 2015-02-17'. The main content area is a grid of tiles:

Channel 1 26.1°C alarm none min: 26.1°C max: 26.3°C	Channel 2 30.9%RH alarm low min: 30.7%RH max: 31.4%RH	History .CSV dot file	Events .CSV dot file
Channel 3 76.1°F alarm none min: 75.7°F max: 76.3°F	Channel 4 n/a alarm none min: n/a max: n/a	History .CSV comma file	Events .CSV comma file
Door closed alarm none	Flood sensor normal alarm none	MinMax mem	Mobile web
Power supply off alarm none		Events viewer	Settings *
			About ?

Copyright © 2015, Comet system s.r.o. All rights reserved.

General

Device name can be changed using item **Device name**. Measured values are stored into memory according **History storage interval** field. After changing of this interval all history values will be cleared. Changes must be confirmed by **Apply settings** button.

Settings **General**

Back
Exit to main menu

General
General device settings

Network
Basic settings of the network interface

Backup
Save or restore configuration

Maintenance
Factory defaults, info, etc.

General device settings. Device name can be changed to user specified name. History graphs and tables will be cleared after changing history storage interval.

Device name

History storage interval

Apply settings Cancel changes

Network

Network parameters can be obtained automatically from DHCP server using option **Obtain an IP address automatically**. Static IP address is configurable via field **IP address**. It is not necessary setup **Default gateway** while you use device inside one subnet only. **DNS server IP** is required to set for proper function of DNS. Option **Standard subnet mask** sets network mask automatically according to A, B or C network class. **Subnet mask** field must be set manually when network with non-standard range is used. **Periodic restart interval** enables to restart device after selected time since device start.

Settings **Network**

Back
Exit to main menu

General
General device settings

Network
Basic settings of the network interface

Alarm limits
Configuration of the alarm limits

Backup
Save or restore configuration

Maintenance
Factory defaults, info, etc.

Basic settings of the network interface. IP address can be set as either static or obtained automatically by the DHCP server. After saving the setting, device will be rebooted automatically. Before changing IP address, please contact your network administrator.

Obtain an IP address automatically

IP address

Default gateway

DNS server IP

Standard subnet mask

Subnet mask

Periodic restart interval

Apply settings Cancel changes

Alarm limits

For each measurement channel is possible to set upper and lower limits, time-delay for alarm activation and hysteresis for alarm clearing.

Back
Exit to main menu

General
General device settings

Network
Basic settings of the network interface

Alarm limits
Configuration of the alarm limits

Channels
General settings of the channels

Backup
Save or restore configuration

Maintenance
Factory defaults, info, etc.

Settings Alarm limits

Configuration of the alarm limits. The safe range is between high and low limit. Alarm condition occurs while measured value is out of the safe range for selected time delay. Alarm is cleared if measured value returns to safe range with hysteresis.

Channel 1 limits
Channel name: Channel 1
Current value: 24.6 °C
User adjustment: no

High limit [°C]	Low limit [°C]	Hysteresis [°C]	Time delay [sec]
50.0	0.0	1.0	30

Channel 2 limits
Channel name: Channel 2
Current value: 47.4 %RH
User adjustment: no

High limit [%RH]	Low limit [%RH]	Hysteresis [%RH]	Time delay [sec]
50.0	0.0	1.0	30

Apply settings
Cancel changes

Example of setting the limit to the upper alarm limit:

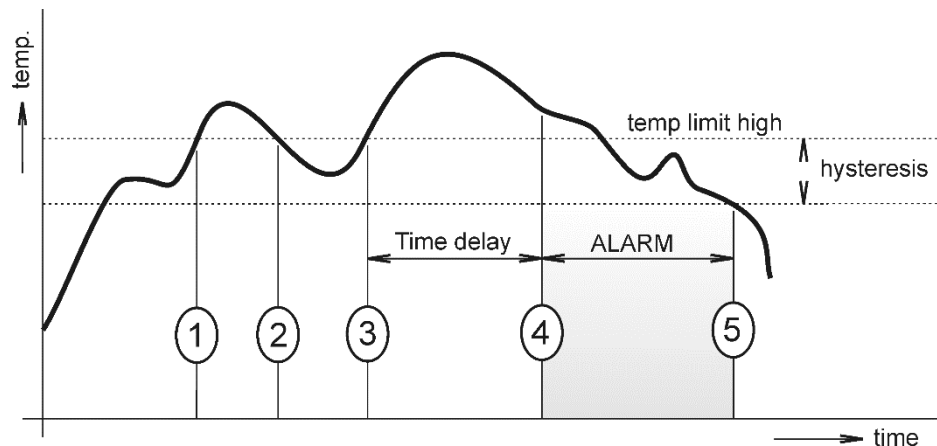

In Point 1 the temperature exceeded the limit. From this time, the time-delay is counting. Because at point 2 the temperature dropped below the limit value before the time delay expired, alarm was not set.

In Point 3 the temperature has risen over limit again. During the time-delay the value does not drop below the set limit, and therefore was in Point 4 caused alarm. At this moment were sent e-mails, traps and set alarm flag on website, SNMP and Modbus.

The alarm lasted up to Point 5, when the temperature dropped below the set hysteresis (temperature limit – hysteresis). At this moment was active alarm cleared and e-mail send.

When alarm occurs, alarm messages will be sent. In case of power failure or device reset (e.g. changing the configuration) will new alarm state evaluated and new alarm messages will be send.

Channels

Channel can be enabled or disabled for measuring using item **Enabled**. Channel can be renamed (max. 14 characters) and it is possible select unit of measured value according to connected probe type. When channel is not used, it is possible copy to it one of other channels – option **Clone channel**. This option is not available at fully occupied device. **Find sensors** button starts searching for connected probes. All changes must be confirmed using **Apply settings** button. History values are cleared after changing of channel settings.

Back
Exit to main menu

General
General device settings

Network
Basic settings of the network interface

Alarm limits
Configuration of the alarm limits

Channels
General settings of the channels

BIN Inputs
Binary inputs settings

Backup
Save or restore configuration

Maintenance
Factory defaults, info, etc.

Settings Channels

General settings of the channels. Find sensors button starts search for connected probes. Connected probes can be cloned to unused channels. To change order of ROM codes Drag and Drop feature can be used. History values of the channel will be cleared immediately after changing channel settings.

Channel 1
ROM code: 28 F3 AE 56 07 00 00 0F
Sensor: temperature probe

Enabled Channel 1 temperature [°C] ▾

Channel 2
ROM code: 26 98 B5 FA 01 00 00 2D
Sensor: humidity+temperature probe

Enabled Channel 2 humidity [%RH] ▾

Apply settings
Find sensors
Clear channels
Cancel changes

Binary inputs

Binary inputs can be enabled or disabled for states evaluation by the **Enable** option. Name of the binary input is configurable (max. 14 characters). **Closed state description / High voltage description / Flood state** allows to change name of binary input in the closed state. Open state has name according to **Open state description / Low voltage description / Dry state** field. Alarm states are evaluated according set **Time delay for alarm**. It can be selected that alarm is active at closed or open state of binary input. Alarms on binary inputs can be disabled also.

Type of binary input is selectable – option **Input type**. Dry contact is a default option and allows to use input with door contacts and sensors with relay output. Voltage contact option can be used with sensors like an AC detector SP008. Device P8653 have first binary input reserved for flood detector LD-81.

[Back](#)
Exit to main menu

Settings

Inputs

General
General device settings

Network
Basic settings of the network interface

Alarm limits
Configuration of the alarm limits

Channels
General settings of the channels

BIN Inputs
Binary inputs settings

SOAP protocol
Setup SOAP protocol for database system

Email
Alarm emails configuration

Protocols
Syslog and ModbusTCP protocol settings

SNMP
SNMPv1 protocol and SNMP Traps

Time
Synchronization with NTP server

WWW and Security
Web server and Security configuration

MinMax memory
Timestamps, clear memory

Backup
Save or restore configuration

Maintenance
Factory defaults, info, etc.

Binary inputs settings. Alarms on binary inputs are evaluated by the selected alarm level (Alarm on) and time delay for alarm. Dry contact option should be selected for door contacts and sensors with relay output. Voltage contact is available for sensors with voltage output like a AC voltage detector SP008.

Binary Input 1

Enabled Door

Closed state description closed

Open state description open

Time delay for alarm [sec] 2

Alarm on Closed state

Input type Dry contact

Binary Input 2

Enabled Binary Input 2

Binary Input 3

Enabled Power supply

High voltage description ok

Low voltage description fail

Time delay for alarm [sec] 2

Alarm on Low voltage

Input type Voltage contact

Apply settings Cancel changes

SOAP protocol

SOAP protocol can be enabled by option **SOAP protocol enabled**. Destination SOAP server can be set via **SOAP server address**. For setup of server port can be used option **SOAP server port**. Device sends SOAP message according selected **Sending interval**. Option **Send SOAP message when alarm occurs** sends message when an alarm on channel occurs or alarm is cleared. These SOAP messages are sent asynchronously to selected interval.

Back
Exit to main menu

Settings SOAP

Setup SOAP protocol for database system. Current measured values are sent as XML files. For more information please read the user guide for database system.

SOAP protocol enabled

SOAP server address

SOAP server port

Sending interval

Send SOAP message when alarm occurs

General
General device settings

Network
Basic settings of the network interface

Alarm limits
Configuration of the alarm limits

Channels
General settings of the channels

BIN Inputs
Binary inputs settings

SOAP protocol
Setup SOAP protocol for database system

Email
Alarm emails configuration

Backup
Save or restore configuration

Maintenance
Factory defaults, info, etc.

Email

Email sending enabled option allows e-mail features. It is necessary set address of the SMTP server into **SMTP server address** field. Domain name for SMTP server can be used. Default port of the SMTP server can be changed using item **SMTP server port**. SMTP authentication can be enabled using **SMTP authentication** option. When authentication is enabled **Username** and **Password** must be set.

For successfully e-mail sending it is necessary insert **Email sender address**. This address is usually same as username of the SMTP authentication. Into fields **Recipient 1** to **Recipient 3** it is possible set address of e-mail recipients. Option **Short email** enable sending e-mails in short format. This format is usable when you need to forward e-mails into SMS messages.

When option **Alarm email repeat sending interval** is enabled and there is active alarm on channel, then e-mails with actual values are sent repeatedly. **Info email sending interval** option enables sending e-mails at selected time interval. CSV history file can be sent together with the repeat/info e-mails. This feature can be enabled by **Alarm and Info emails attachment** option.

It is possible to test e-mail function using button **Apply and test**. This button saves a new settings and sends a testing e-mail immediately.

Back
Exit to main menu

Settings

Email

General
General device settings

Network
Basic settings of the network interface

Alarm limits
Configuration of the alarm limits

Channels
General settings of the channels

BIN Inputs
Binary inputs settings

SOAP protocol
Setup SOAP protocol for database system

Email
Alarm emails configuration

Protocols
Syslog and ModbusTCP protocol settings

SNMP
SNMPv1 protocol and SNMP Traps

Time
Synchronization with NTP server

WWW and Security
Web server and Security configuration

MinMax memory
Timestamps, clear memory

Backup
Save or restore configuration

Maintenance
Factory defaults, info, etc.

Configuration of the alarm emails. Device can send warning email when alarm on measured channel occurs. Email is also sent when alarm condition is cleared.

Email sending enabled

SMTP server configuration
For proper email sending it is necessary to setup connection to your SMTP server. SMTP authentication can be used if needed. For information about SMTP server settings please contact your network administrator or ISP.

SMTP server address

SMTP server port

SMTP authentication

Username

Password

Email configuration
Setup up to three address for email recipients. Sender address is usually the same as the username of the SMTP authentication.

Email sender address

Recipient 1

Recipient 2

Recipient 3

Short email

Alarm email repeat sending interval

Info email sending interval

Alarm and Info emails attachment

Modbus a Syslog protocols

ModbusTCP and Syslog protocol settings are configurable via menu **Protocols**. Modbus server is enabled by default. Deactivation is possible via **Modbus server enabled** option. Modbus port can be changed via **Modbus port** field. Syslog protocol can be enabled using item **Syslog enabled**. Syslog messages are sent to IP address of the Syslog server - field **Syslog server IP address**.

Back
Exit to main menu

Settings Protocols

General
General device settings

Email
Alarm emails configuration

Protocols
Syslog and ModbusTCP protocol settings

SNMP
SNMPv1 protocol and SNMP Traps

ModbusTCP protocol
Configuration of the ModbusTCP protocol. Current measured values can be read using ModbusTCP protocol. Modbus registers are described inside the user manual.

Modbus server enabled

Modbus port

Syslog protocol
Configuration of the Syslog protocol. Alarm messages can be sent to the Syslog server using UDP protocol.

Syslog enabled

Syslog server IP address

Apply settings Cancel changes

SNMP

For reading values via SNMP it is necessary to know password - **SNMP read community**. SNMP Trap can be delivered up to three IP address - **IP address of the Trap recipient**. SNMP Traps are sent at alarm or error state on the channel. Trap feature can be enabled by option **Trap enabled**.

Back
Exit to main menu

Settings SNMP

General
General device settings

Protocols
Syslog and ModbusTCP protocol settings

SNMP
SNMPv1 protocol and SNMP Traps

Time
Synchronization with NTP server

WWW and Security
Web server and Security configuration

Configuration of the SNMPv1 protocol and SNMP Traps. Current measured values can be read using SNMP protocol. When alarm on channel occurs a warning message (Trap) can be sent to selected IP addresses.

SNMP read community

System location

Trap enabled

IP address of the Trap recipient 1

IP address of the Trap recipient 2

IP address of the Trap recipient 3

Apply settings Cancel changes

Time

Time synchronization with SNTP server can be enabled by **Time synchronization enabled** option. IP address of the SNTP is necessary to set into **SNTP server IP address** item. List of free NTP servers is available at www.pool.ntp.org/en. SNTP time is synchronized at UTC format, and due to be necessary set corresponding time offset - **GMT offset [min]**. Time is

synchronized every 24 hours by default. Option **NTP synchronization every hour** decreases this synchronization interval to one hour.

Settings Time

Time can be synchronized according the SNTP server. To correct time is necessary set GMT offset of your time zone. Time synchronisation is required for timestamps inside CSV files.

Time synchronised with server yes (at 13:50:48 2017-10-23)

Time synchronization enabled

SNTP server IP address

GMT offset [min]

NTP synchronization every hour

Apply settings Cancel changes

WWW and security

Security features can be enabled by the **Security enabled** option. When security is enabled, it is necessary to set administrator password. This password will be required for device settings. When secured access is required even to actual values reading it is possible to enable **User account only for viewing**. Port of the www server can be changed from the default value 80 using field **WWW port**. Web pages with actual values are refreshed according to **Web refresh interval** field.

Settings WWW and Security

Security
Configuration of the secure access to the device. Administrator password must be inserted if security is enabled. Administrator password is used for device configuration. User password is used only for measured values viewing.

Security enabled

Web server
Configuration of the embedded web server. Web server can be disabled by TSensor software.

Web server enabled

WWW port

Web refresh interval

Apply settings Cancel changes

Memory for minimal and maximal values

Minimal and maximal measured values are stored into the memory. This memory is independent from values stored in history memory (charts). Memory for minimal and

maximal values is cleared in case of device restart or by the user request. In case of device time is synchronized with SNTP server, timestamps for minimal and maximal values are available.

Backup and restore configuration

Device configuration can be saved into file and restored if needed. Compatible parts of configuration can be uploaded into another device type. Configuration can be moved only within devices at same family. It is not possible restore configuration from p-line Web Sensor into t-line Web Sensor and conversely.

Setup using TSensor software

TSensor software is an alternative to the web configuration. Some less important parameters are configurable by the TSensor software only.

Parameter **MTU size** can reduce size of the Ethernet frames. Lowering of this size can solve some communication problems mainly when VPN is used. TSensor software can set offset of values at temperature probes. At DSRH humidity probes is possible set correction of the humidity and temperature.

Factory defaults

Factory defaults button set the device into factory configuration. Network parameters (IP address, Subnet mask, Gateway, DNS) are left without changes.

Back
Exit to main menu

Settings

Maintenance

General
General device settings

Network
Basic settings of the network interface

Alarm limits
Configuration of the alarm limits

Channels
General settings of the channels

BIN Inputs
Binary inputs settings

SOAP protocol
Setup SOAP protocol for database system

Email
Alarm emails configuration

Protocols
Syslog and ModbusTCP protocol settings

SNMP
SNMPv1 protocol and SNMP Traps

Time
Synchronization with NTP server

WWW and Security
Web server and Security configuration

MinMax memory
Timestamps, clear memory

Backup
Save or restore configuration

Maintenance
Factory defaults, info, etc.

Info
Basic informations about device. Find more detailed information on the diagnostic page. Please send the diagnostic file together with request to support.

Device type	P8652	
Serial number	15942487	
MAC address	00-80-A3-93-6D-C9	
Firmware version	4-5-8-1.3502 / 1.80	
Build firmware notice	Bay cat	
Device uptime	0 h, 28 min, 53 sec	
Diagnostic file	192.168.1.122/diag.log	

Events Logs
Events logs with the system or alarm messages can be downloaded in CSV file format for further analysis. After request confirmation both logs are cleared together.

Alarm events log
System events log
Clear events logs

Restart
Device will be restarted after dialog confirmation. All history values are cleared after restart. Restarting of the device will take a few seconds.

Restart device

Factory defaults
Factory defaults button restores device to factory settings. Network parameters like a IP address, subnet mask and gateway IP will not be changed.

Factory defaults

Network parameters are changed when factory default button is pressed during device power on (in more detail – see Chapter 5).

Parameter	Value
SMTP server address	example.com
SMTP server port	25
Alarm e-mail repeat sending interval	off
Info e-mail repeat sending interval	off
Alarm and Info e-mails attachment	off
Short e-mail	off
E-mail recipients addresses	cleared
E-mail sender	sensor@websensor.net
SMTP authentication	off
SMTP user/SMTP password	cleared
E-mail sending enabled	off
IP addresses SNMP traps recipients	0.0.0.0
System location	cleared
Password for SNMP reading	public
Sending SNMP Trap	off
Website refresh interval [sec]	10
Website enabled	yes
Website port	80
Security	off
Administrator password	cleared
User password	cleared
Modbus TCP protocol port	502
Modbus TCP enabled	yes
History storage interval [sec]	60
SOAP message when alarm occurs	yes
SOAP destination port	80
SOAP server address	cleared
SOAP sending interval [sec]	60
SOAP protocol enabled	off
Syslog server IP address	0.0.0.0
Syslog protocol enabled	off
SNTP server IP address	0.0.0.0
GMT offset [min]	0
NTP synchronization every hour	off
SNTP synchronization enabled	off
MTU	1400
Periodic restart interval	off
Demo mode	off
Upper limit	50
Lower limit	0
Hysteresis – hysteresis for alarm clearing	1
Delay – time-delay of alarm activation [sec]	30
Channel enabled	all channels
Unit on the channel	°C or %RH according used probe
Channel name	Channel X (where X is 1 to 5)
Enabled binary channels	all inputs
Binary channel name	BIN input X (where X is 1 to 3)
Binary input alarm on	closed

Input type	dry contact
Time-delay for binary input [sec]	2
Closed state description	on
Open state description	off
Device name	Web sensor

Communication protocols

Short introduction to communication protocols of the device. To use some communication protocols is necessary software, which can use the protocol. This software is not included. For detailed description of protocols and application notes please contact your distributor.

Website

The device supports displaying of measured values, history graphs and configuration using web browser. History graphs are based on HTML5 canvas. Web browser must support this feature for proper function of graphs. Firefox, Opera, Chrome, or Edge can be used. If the device has set IP address **192.168.1.213** type into your browser **http://192.168.1.213**. Automatic refresh interval of the web pages can be changed from default value 10sec. Actual measured values can be obtained using XML file **values.xml** and JSON file **values.json**.

Values from history can be exported in CSV format. Interval of storing values into internal history memory is configurable also. History is erased after every reboot of the device. Reboot of the device is performed when the power supply is disconnected and when configuration change.

SMTP – sending e-mails

When measured values are over the set limits, the device allows send e-mail to a maximum of 3 addresses. E-mail is sent when alarm condition on the channel is cleared or a measuring error occurs. It is possible to set repeat interval for e-mail sending. For correct sending of e-mails it is necessary to set address of SMTP server. Domain address can be used as SMTP server address too. For proper function of DNS is required to set DNS server IP address. SMTP authentication is supported but SSL/STARTTLS not. Standard SMTP port 25 is used by default. SMTP port can be changed. Contact your network administrator to obtain configuration parameters of your SMTP server. E-mail sent by the device cannot be answered.

SNMP

Using SNMP protocol you can read actual measured values, alarm status and alarm parameters. Via SNMP protocol is also possible to get last 1000 measured values from history table. Writing via SNMP protocol is not supported. It is supported **SNMPv1** protocol only. SNMP used **UDP port 161**. OID keys description can be found in the MIB table. It can be obtained from device website or from your distributor. The password for reading is set to **public** as default. Filed **System location** (OID 1.3.6.1.2.1.1.6 - sysLocation) is blank by default. The changes can be made using web interface. OID keys:

OID	Description	Type
.1.3.6.1.4.1.22626.1.5.1	Device information	
.1.3.6.1.4.1.22626.1.5.1.1.0	Device name	String
.1.3.6.1.4.1.22626.1.5.1.2.0	Serial number	String
.1.3.6.1.4.1.22626.1.5.1.3.0	Device type	Integer
.1.3.6.1.4.1.22626.1.5.2.ch	Measured value (where ch=1-channel 1, etc.)	
.1.3.6.1.4.1.22626.1.5.2.ch.1.0	Channel name	String
.1.3.6.1.4.1.22626.1.5.2.ch.2.0	Actual value – text	String
.1.3.6.1.4.1.22626.1.5.2.ch.3.0	Actual value	Int*10
.1.3.6.1.4.1.22626.1.5.2.ch.4.0	Alarm on channel (0/1/2)	Integer
.1.3.6.1.4.1.22626.1.5.2.ch.5.0	High limit	Int*10
.1.3.6.1.4.1.22626.1.5.2.ch.6.0	Low limit	Int*10
.1.3.6.1.4.1.22626.1.5.2.ch.7.0	Hysteresis	Int*10
.1.3.6.1.4.1.22626.1.5.2.ch.8.0	Delay	Integer
.1.3.6.1.4.1.22626.1.5.2.ch.9.0	Unit	String
.1.3.6.1.4.1.22626.1.5.2.ch.10.0	Alarm on channel – text	String
.1.3.6.1.4.1.22626.1.5.2.ch.11.0	Minimal value on channel	String
.1.3.6.1.4.1.22626.1.5.2.ch.12.0	Maximal value on channel	String
.1.3.6.1.4.1.22626.1.5.2.bin	Binary input (where bin=6-BIN1, bin=10-BIN5)	
.1.3.6.1.4.1.22626.1.5.2.bin.1.0	Binary input name	String
.1.3.6.1.4.1.22626.1.5.2.bin.2.0	State of binary input – text	String
.1.3.6.1.4.1.22626.1.5.2.bin.3.0	State of binary input	Integer
.1.3.6.1.4.1.22626.1.5.2.bin.4.0	Alarm on binary input – text	String
.1.3.6.1.4.1.22626.1.5.2.bin.5.0	Alarm on binary input (0/1)	Integer
.1.3.6.1.4.1.22626.1.5.3.1.0	SNMP Trap text	String
.1.3.6.1.4.1.22626.1.5.4.1.1.ch.nr	History table value (nr-sample number)	Int*10

When alarm occurred a warning message (trap) can be sent to selected IP addresses. Addresses can be set using web interface. Traps are sent via **UDP** protocol on **port 162**. The device can send following traps:

Trap	Description	
0/0	Reset of the device	
6/0	Testing Trap	
6/1	NTP synchronization error	
6/2	E-mail sending error	SMTP server login error
6/3		SMTP authentication error
6/4		Some error occurred during SMTP communication
6/5		TCP connection to server cannot be opened
6/6		SMTP server DNS error
6/7	SOAP message sending error	SOAP file not found inside web memory
6/8		MAC address can't be obtained from address
6/9		TCP connection to server cannot be opened
6/10		Wrong response code from the SOAP server
6/11 – 6/15	Upper alarm on channel	
6/21 – 6/25	Lower alarm on channel	
6/31 – 6/35	Clearing alarm on channel	
6/41 – 6/45	Measuring error	
6/51 – 6/55	Alarm on binary input	
6/61 – 6/65	Clearing alarm on binary input	

Modbus TCP

Device supports Modbus protocol for communication with SCADA systems. Device use Modbus TCP protocol. **TCP port** is set to **502** by default. Port can be changed using web interface. Only two Modbus clients can be connected to device at one moment. Modbus device address (Unit Identifier) can be arbitrary. Modbus write command is not supported. Specification and description of the Modbus protocol is free to download at: www.modbus.org.

Supported Modbus commands (functions):

Command	Code	Description
Read Holding Register (s)	0x03	Read 16b register(s)
Read Input Register(s)	0x04	Read 16b register(s)

Modbus device registers. Address could be by 1 higher, depending on type used communication library:

Address [DEC]	Address [HEX]	Value	Type
39970	0x9C22	1st two digits from serial number	BCD
39971	0x9C23	2nd two digits from serial number	BCD
39972	0x9C24	3rd two digits from serial number	BCD
39973	0x9C25	4th two digits from serial number	BCD
39974	0x9C26	Device type	uInt
39975 – 39979	0x9C27 – 0x9C2B	Actual measured value on channel	Int*10
39980 – 39984	0x9C2C – 0x9C30	Unit on the channel	Ascii
39985 – 39989	0x9C31 – 0x9C35	Channel alarm state	uInt
39990 – 39994	0x9C36 – 0x9C3A	Binary input state	uInt
39995 – 39999	0x9C3B – 0x9C3F	Binary input alarm state	uInt
40000	0x9C40	Channel 1 temperature or humidity	Int*10
40001	0x9C41	Channel 1 alarm status	Ascii
40002	0x9C42	Channel 1 upper limit	Int*10
40003	0x9C43	Channel 1 lower limit	Int*10
40004	0x9C44	Channel 1 hysteresis	Int*10
40005	0x9C45	Channel 1 delay	uInt
40006	0x9C46	Channel 2 temperature or humidity	Int*10
40007	0x9C47	Channel 2 alarm status	Ascii
40008	0x9C48	Channel 2 upper limit	Int*10
40009	0x9C49	Channel 2 lower limit	Int*10
40010	0x9C4A	Channel 2 hysteresis	Int*10
40011	0x9C4B	Channel 2 delay	uInt
40012	0x9C4C	Channel 3 temperature or humidity	Int*10
40013	0x9C4D	Channel 3 alarm status	Ascii
40014	0x9C4E	Channel 3 upper limit	Int*10
40015	0x9C4F	Channel 3 lower limit	Int*10
40016	0x9C50	Channel 3 hysteresis	Int*10
40017	0x9C51	Channel 3 delay	uInt
40018	0x9C52	Channel 4 temperature or humidity	Int*10
40019	0x9C53	Channel 4 alarm status	Ascii
40020	0x9C54	Channel 4 upper limit	Int*10
40021	0x9C55	Channel 4 lower limit	Int*10
40022	0x9C56	Channel 4 hysteresis	Int*10
40023	0x9C57	Channel 4 delay	uInt

Description:

Int*10	registry is in format integer*10 – 16 bits
uInt	registry range is 0-65535
Ascii	character
BCD	registry is coded as BCD
n/a	item is not defined, should be read

Possible alarm states (Ascii):

no	no alarm
lo	value is lower than set limit
hi	value is higher than set limit

SOAP

The device allows you to send currently measured values via **SOAP v1.1** protocol. The device sends values in XML format to the web server. The advantage of this protocol is that communication is initialized by the device side. Due to it is not necessary use port forwarding. If the SOAP message cannot be delivered, warning message via SNMP Trap or Syslog protocol is sent. The file with the XSD schema can be downloaded from: <http://cometsystem.cz/schemas/soapP8xxxBinIn.xsd>. SOAP message example:

```
<?xml version="1.0" encoding="utf-8"?>
<soap:Envelope xmlns:soap="http://schemas.xmlsoap.org/soap/envelope/"
xmlns:xsi="http://www.w3.org/2001/XMLSchema-instance"
xmlns:xsd="http://www.w3.org/2001/XMLSchema">
  <soap:Body>
    <InsertP8xxxBinInSample xmlns="http://cometsystem.cz/schemas/soapP8xxxBinIn.xsd">

      <name>Web Sensor</name>
      <sn>14969090</sn>
      <tmr>10</tmr>
      <kind>4360</kind>

      <c i="1">
        <e>1</e>
        <n>freezer</n>
        <u>C</u>
        <p>1</p>
        <v>-10.4</v>
        <a>no</a>
        <h>-5.0</h>
        <l>-20.0</l>
      </c>

      ...
      ...
      ...

      <c i="5">
        <e>0</e>
        <n>Channel 5</n>
        <u>n/a</u>
        <p>1</p>
        <v>-11000</v>
        <a>no</a>
        <h>50.0</h>
        <l>0.0</l>
      </c>

      <b i="6">
        <e>1</e>
        <n>Door 1</n>
        <b0>open</b0>
        <b1>closed</b1>
        <v>0</v>
        <a>no</a>
      </b>

      ...
      ...

      <b i="8">
        <e>1</e>
        <n>power</n>
        <b0>fail</b0>
        <b1>OK</b1>
        <v>0</v>
        <a>ac</a>
      </b>

    </InsertP8xxxBinInSample>
  </soap:Body>
</soap:Envelope>
```

Element		Description								
General elements	<name>	Device description.								
	<sn>	Contains the device serial number (an eight digit number).								
	<tmr>	SOAP sending interval [sec].								
	<kind>	Device type identification number (code):								
		<table border="1"> <thead> <tr> <th>Device</th> <th>Code [DEC]</th> </tr> </thead> <tbody> <tr> <td>P8652</td> <td>4360</td> </tr> <tr> <td>P8552</td> <td>4361</td> </tr> <tr> <td>P8653</td> <td>4362</td> </tr> </tbody> </table>	Device	Code [DEC]	P8652	4360	P8552	4361	P8653	4362
	Device	Code [DEC]								
P8652	4360									
P8552	4361									
P8653	4362									
Channel elements	<e>	Information about enabled/disabled channel (1 – enabled/ 0 – disabled).								
	<n>	Name of channel.								
	<u>	Channel unit (C, F or RH) In case of error n/a text is shown.								
	<p>	Count of the decimal places. Always 1 .								
	<v>	Actual measured value (a decimal part of number is separated by a dot). Error on channel has number -11000 or lower.								
	<a>	Alarm state, where no – no alarm, hi – high alarm, lo – low alarm.								
	<h>	Preset high limit on channel.								
	<l>	Preset low limit on channel.								
BIN input elements	<e>	Information about enabled/disabled binary input (1 – enabled/ 0 – disabled).								
	<n>	Name of binary input.								
	<b0>	Description for binary input state „ 0 “.								
	<b1>	Description for binary input state „ 1 “.								
	<v>	Current state of binary input (0, 1 or -11000).								
	<a>	Alarm state, where no – no alarm, ac – active alarm.								

Syslog

The device allows sending text message to selected Syslog server. Events are send using **UDP** protocol on **port 514**. Syslog protocol implantation is according to RFC5424 and RFC5426. Events when Syslog messages are send:

Text	Event
Sensor - fw 4-5-8.x	Reset of the device
NTP synchronization error	NTP synchronization error
Testing message	Test Syslog message
Email login error	E-mail sending error
Email auth error	
Email some error	
Email socket error	
Email dns error	
SOAP file not found	SOAP message sending error
SOAP host error	
SOAP sock error	
SOAP delivery error	
SOAP dns error	
High alarm CHx	Upper alarm on channel
Low alarm CHx	Lower alarm on channel
Clearing CHx	Clearing alarm on channel
Error CHx	Measuring error
Alarm BINx	Alarm on binary input
Clearing BINx	Clearing alarm on binary input

SNTP

The device allows time synchronization with NTP (SNTP) server. SNMP protocol version 3.0 is supported (RFC1305). Time synchronization is made every 24 hours. Time synchronization every hour can be enabled. For time synchronization it is necessary set IP address to the SNTP server. It is also possible set GMT offset for correct time zone. Time is used in graphs and history CSV files. Maximum jitter between two time synchronization is 90sec at 24 hours interval.

Software development kit

Device provides on own web pages documentation and examples of usage protocols. SDK files are available at library page (About – Library).

SDK File	Note
snmp.zip	Description of SNMP OID's and SNMP Traps, MIB tables.
modbus.zip	Modbus registers numbers, example of get values from the device by Python script.
xml.zip	Description of file values.xml, examples of values.xml file, XSD schematic, Python example.
json.zip	Description of values.json file, example of values.json file, Python example.
soap.zip	Description of SOAP XML format, example of SOAP messages, XSD schematic, examples of get SOAP values at .net, PHP and Python.
syslog.zip	Description of syslog protocol, simple syslog server in Python.

Troubleshooting

The chapter describes the common problems with Web Sensor P8552, Web Sensor P8652, Web Sensor P8653 and methods how to fix these problems. Please read this chapter before you will call technical support.

I forgot the device IP address

IP address is factory set to **192.168.1.213**. If you had changed it and forgot new IP address, run the TSensor software and press **Find device...** In the window are displayed all available devices.

I cannot connect to the device

In search window is only IP and MAC address displayed

Other details are marked **N/A**. This problem occurs if IP address of the device is set to another network.

Select the window **Find device** in TSensor software and press **Change IP address**. Follow the software instructions. To assign IP address automatically using DHCP server, set the device IP address to **0.0.0.0**.

Device IP address is not displayed in window Find device

In TSensor software menu press **Help! My device was not found!** in window **Find device**. Follow the software instructions. MAC address of the device can be found on product label.

The device is not found even after manually setting MAC address

This problem occurs especially in cases when the IP address of the device belongs to another network and also Subnet mask or Gateway are incorrect.

In this case is DHCP server in the network necessary. In TSensor software menu press **Help! My device was not found!** in window **Find device**. As new IP address set **0.0.0.0**. Follow the software instructions. An alternative is to reset device to factory defaults using factory-defaults button.

Error or n/a is displayed instead the measured value

Value **n/a** is shown a shortly after device restart. If the error code or **n/a** is displayed permanently, check if the probes are connected to device correctly. Make sure that probes are not damaged and are inside operating range. Then perform new search of probes using web interface. List of error codes:

Error	Code	Description	Note
n/a	-11000	Value is not available.	Code is shown after device restart or when channel is not enabled for measurement.
Error 1	-11001	No probe was detected on measurement bus.	Make sure that probes are connected properly, and cables are not damaged.
Error 2	-11002	Short circuit on measurement bus was detected.	Please make sure that cables of probes are not damaged. Check if correct probes are connected. Probes Pt100/Pt1000 and Ni100/Ni1000 cannot be used with this device.
Error 3	-11003	Values cannot be read from probe with ROM code stored in device.	According to ROM code on probe label please make sure that is connected proper probe. Please make sure that cables of probes are not damaged. Probes with new ROM code is necessary detect again.
Error 4	-11004	Communication error (CRC).	Make sure that cables of probe are not damaged, and cables are not longer than is allowed. Make sure that cable of probe is not located near the source of EM interferences (power lines, frequency inverters, etc.).
Error 5	-11005	Error of minimal measured values from probe.	Device measured lower or higher values than is allowed. Please check place of probe installation. Make sure that probe is not damaged.
Error 6	-11006	Error of maximal measured values from probe.	
Error 7	-11007	Power supply error at humidity probe or measurement error at temperature probe	Contact technical support. Please send together with issue description the diagnostic file \diag.log.
Error 8	-11008	Voltage measurement error at humidity probe.	
Error 9	-11009	Unsupported probe type.	Please contact technical support of local distributor to get firmware update for the device.

Binary inputs do not show the correct values

Probably is selected wrong type of binary input. Please switch input type on web interface. Option **Dry contact** should be used for potential-less inputs like a door contact. Switch to **Voltage contact** in case of using AC voltage detector SP008. Flood detector LD-81 can be connected to first binary input of P8653 only. Flood detector LD-81 is not compatible with devices P8652 and P8652.

I forgot the password for setup

Please reset device to factory defaults. Procedure is described at following point.

Factory defaults

This procedure restore device to factory settings including network parameters (IP address, Subnet mask, etc.). For factory-defaults follow these steps:

- disconnect the power supply (power adapter or RJ45 connector if PoE is used)
- use something with thin tipped (e.g. paper clip) and press the hole on the left side

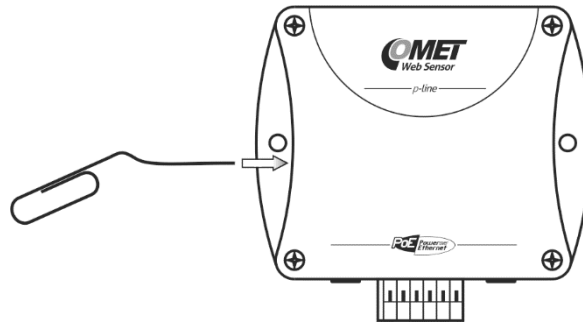

- connect the power, wait for 10sec and release the button.

Technical specifications

Information about technical specifications of the device.

Dimensions

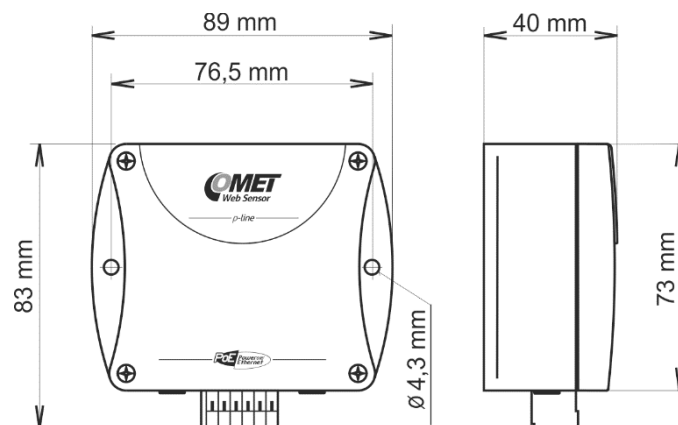

Basic parameters

Supply voltage P8552:

DC voltage from 4.9V to 6.1V, coaxial connector, 5x 2.1mm diameter, center positive pin, min. 250mA

Supply voltage P8652 and P8653:

Power over Ethernet according to IEEE 802.3af, PD Class 0 (max. 12.95W), voltage from 36V to 57V DC. For PoE are used pairs 1, 2, 3, 6 or 4, 5, 7, 8.

or DC voltage from 4.9V to 6.1V, coaxial connector, 5x 2.1mm diameter, positive pole in the middle, min. 250mA

Consumption:

~ 1W depending on the operating mode

Protection:	IP30 case with electronic											
Measuring interval:	2 sec											
Accuracy (depending on used probe – e.g. probe DSTG8/C parameters):	$\pm 0.5^{\circ}\text{C}$ in temperature range from -10°C to $+85^{\circ}\text{C}$ $\pm 2.0^{\circ}\text{C}$ in temperature range from -10°C to -50°C $\pm 2.0^{\circ}\text{C}$ in temperature range from $+85^{\circ}\text{C}$ to $+100^{\circ}\text{C}$											
Resolution:	0.1°C $0.1\% \text{RH}$											
Temperature measurement range (limited by temperature range of used probe):	-55°C to $+100^{\circ}\text{C}$											
Recommended probes:	Temperature probe DSTR162/C max. length 10m Temperature probe DSTGL40/C max. length 10m Temperature probe DSTG8/C max. length 10m Humidity probe DSRH max. length 5m Humidity probe DSRH+ max. length 5m Humidity probe DSRH/C											
Number of channels:	Two cinch/RCA connectors (4 measurement channels in device) Three BIN inputs on WAGO 734 terminals											
Binary input type:	Without galvanic isolation, software configurable input (dry contact or voltage contact). First binary input at P8653 device is dedicated to flood detector LD-81. This input cannot be switched by software.											
Binary inputs parameters – dry contact:	<table> <tr> <td>Voltage on the unclosed contact</td> <td>3.3V</td> </tr> <tr> <td>Current through closed contact</td> <td>0.1mA</td> </tr> <tr> <td>Maximum resistivity of the contact</td> <td>< 5kΩ</td> </tr> </table>		Voltage on the unclosed contact	3.3V	Current through closed contact	0.1mA	Maximum resistivity of the contact	< 5k Ω				
Voltage on the unclosed contact	3.3V											
Current through closed contact	0.1mA											
Maximum resistivity of the contact	< 5k Ω											
Binary inputs parameters – voltage contact:	<table> <tr> <td>Voltage level for “LOW”</td> <td>< 1.0V</td> </tr> <tr> <td>Voltage level for “HIGH”</td> <td>> 2.5V</td> </tr> <tr> <td>Internal resistivity of the voltage source</td> <td>< 2kΩ</td> </tr> <tr> <td>Input voltage range</td> <td>0 to +30V</td> </tr> <tr> <td>Reverse polarity protection</td> <td>yes</td> </tr> </table>		Voltage level for “LOW”	< 1.0V	Voltage level for “HIGH”	> 2.5V	Internal resistivity of the voltage source	< 2k Ω	Input voltage range	0 to +30V	Reverse polarity protection	yes
Voltage level for “LOW”	< 1.0V											
Voltage level for “HIGH”	> 2.5V											
Internal resistivity of the voltage source	< 2k Ω											
Input voltage range	0 to +30V											
Reverse polarity protection	yes											

Binary inputs parameters – flood detector LD-81 (first binary input at P8653):

Designed for connection of two wire flood detector LD-81 only.
Flood detector LD-12, dry contact or voltage contact sensors are not compatible with this input.

Flood sensor LD-81 parameters:

Maximum length of cable 2.5m (can't be extended)

Two wire connection (red wire – active, black wire – GND), directly powered from Web Sensor P8653

Intended for indoor usage only

Communication port:

RJ45 connector, 10Base-T/100Base-TX Ethernet (Auto-Sensing)

Recommended Connector Cable:

For industrial use is recommended Cat5e STP cable, in less demanding applications can be replaced by Cat5 cable, maximum cable length 100 m

Supported protocols:

TCP/IP, UDP/IP, ARP, ICMP, DHCP, TFTP, DNS

HTTP, SMTP, SNMPv1, ModbusTCP, SNTP, SOAPv1.1, Syslog

SMTP protocol:

SMTP authentication – AUTH LOGIN

Encryption (SSL/TLS/STARTLS) is not supported

Supported web browsers:

Mozilla Firefox 111 and later, Google Chrome 110 and later,
Microsoft Edge 110 and later

Recommended minimum screen resolution:

1024 x 768

Memory:

1000 values for each channel inside non-backup RAM memory

100 values in alarm events log inside non-backup RAM memory

100 values in system events log inside non-backup RAM memory

Case material:

ASA

Mounting the device:

With two holes at the bottom of the unit

Weight:

P8552 ~ 140g, P8652 ~ 145g, P8653 ~145g (LD-81 ~60g)

EMC:

EN 61326-1, EN 55011

Operating terms

Temperature and humidity range in case with electronic for P8652:

-20°C to +60°C, 0 to 100% RH (no condensation)

Temperature and humidity range in case with electronic for P8552:

-30°C to +80°C, 0 to 100% RH (no condensation)

Temperature range of flood sensor LD-81:

-10°C to +40°C

Temperature range of recommended probe DSTR162/C:

-30°C to +80°C

Temperature range of probe DSTGL40/C:

-30°C to +80°C

Temperature range of probe DSTG8/C:

-50°C to +100°C

Temperature range of probe DSRH, DSRH+ and DSRH/C:

0°C to +50°C, 0 to 100% RH (no condensation)

Working position:

arbitrary

End of operation



Disconnect the device and dispose it according to current legislation for dealing with electronic equipment (WEEE directive). Electronic devices must not be disposed of with your household waste and need to be professionally disposed.

Technical support and service

Technical support and service is provided by distributor. Contact is included in warranty certificate.

Preventive maintenance

Make sure the cables and probes are not damaged periodically. Recommended calibration interval is 2 years. Recommended calibration interval for device with humidity probe DSRH, DSRH+ or DSRH/C is 1 year.

Optional accessories

This chapter contains list of optional accessories, which can be ordered by extra cost. Manufacturer recommends using only original accessories.

Temperature probe DSTR162/C

Temperature probe -30 to +80°C with a digital sensor DS18B20 and with Cinch connector for Web Sensor P8552, Web Sensor P8652 and P8653. Accuracy $\pm 0.5^{\circ}\text{C}$ from -10 to +80°C, $\pm 2.0^{\circ}\text{C}$ below -10°C. Length of the plastic case 25mm, diameter 10mm. Guaranteed watertight (IP67), sensor connected to PVC cable with lengths 1, 2, 5 or 10m.

Temperature probe DSTGL40/C

Temperature probe -30 to +80°C with a digital sensor DS18B20 and with Cinch connector. Accuracy $\pm 0.5^{\circ}\text{C}$ from -10 to +80°C, $\pm 2.0^{\circ}\text{C}$ below -10°C. Stainless steel case with length 40mm, diameter 5.7mm. Stainless steel type 17240. Guaranteed watertight (IP67), sensor connected to PVC cable with lengths 1, 2, 5 or 10m.

Temperature probe DSTG8/C

Temperature probe -50 to +100°C with a digital sensor DS18B20 and with Cinch connector. Maximum temperature of the probe is 125°C. Probe accuracy $\pm 0.5^{\circ}\text{C}$ from -10 to +85°C, else $\pm 2.0^{\circ}\text{C}$. Steel steel case with length 40mm, diameter 5.7mm. Stainless steel type 17240. Guaranteed watertight (IP67), sensor connected to silicone cable with lengths 1, 2, 5 or 10m.

Humidity probe DSRH+

DSRH is a relative humidity probe with Cinch connector. Relative humidity accuracy is $\pm 3.5\%RH$ from 10%-90%RH at 25°C. Temperature measuring accuracy is $\pm 0.5^{\circ}\text{C}$. Operating temperature range is 0 to +50°C. Probe length 88mm, diameter 18mm, connected to PVC cable with lengths 1, 2 or 5m.

Humidity-temperature probe DSRH/C

DSRH/C is compact probe for measurement of relative humidity and temperature. Relative humidity accuracy is $\pm 3.5\%RH$ from 10%-90%RH at 25°C. Temperature measuring accuracy is $\pm 0.5^{\circ}\text{C}$. Operating temperature range is 0 to +50°C. Probe length is 100mm and diameter is 14mm. Probe is designed to be directly mounted to device without cable.

Power supply Adapter A1825

Power supply adapter with CEE 7 plug, 100-240V 50-60Hz/5V DC, 1.2A. Adapter must be used if the device is not powered by Ethernet cable.

Device case holder for RACK 19" MP046

MP046 is a universal holder for mounting of Web Sensor P8552, Web Sensor P8652 and Web Sensor P8653 to RACK 19".

Probes holder for RACK 19" MP047

Universal holder for easy mounting probes in RACK 19".

Magnetic door contact SA200A with cable

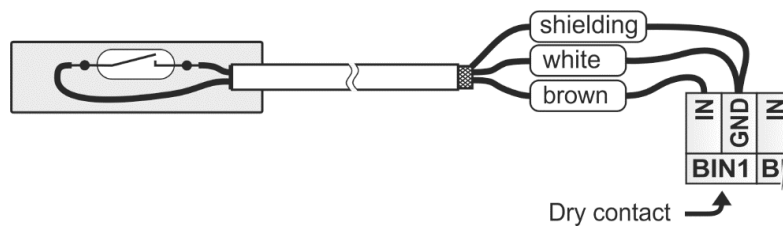

SP008 power detector

SP0008 is AC voltage presence sensor with optical LED indicator. Input voltage: 230 Vac/50 Hz, power plug: type C, response time: approx. 1 sec.

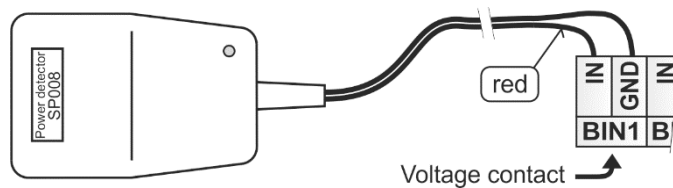

LD-12 flood detector

Water flood detector is designed for a detection of water leakages. This type of flood detector is used with P8552 and P8652 devices. It cannot be used with first binary input at P8653 device. This first binary input is dedicated for flood detector LD-81.

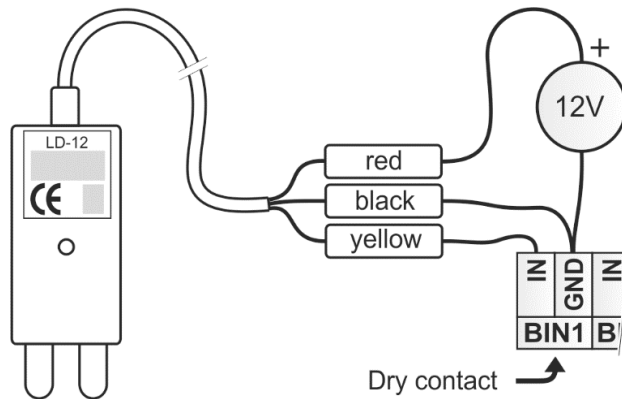

Notice: Before detector installation please read enclosed user guide carefully!

SD-280 optical smoke detector

This device is designed to detect the presence of fire inside residential or commercial buildings.

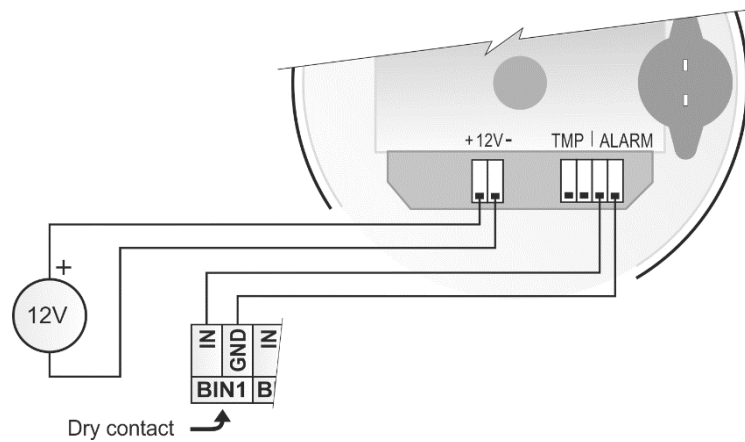

Notice: Before detector installation please read enclosed user guide carefully!

JS-20 PIR motion detector

This P.I.R. motion detector is used to protect interiors.

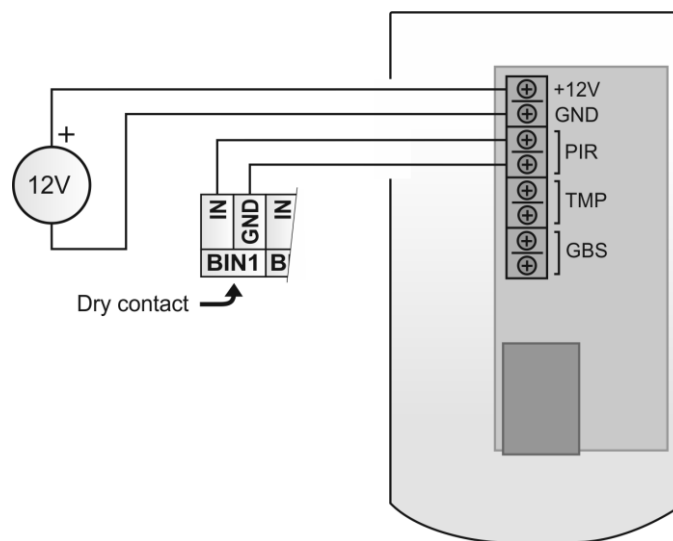

Notice: Before detector installation please read enclosed user guide carefully!

COMET cloud

COMET Cloud is a unique platform that enables the acquisition, storing and analyzing of data from devices manufactured by COMET. Stored data can then be accessed via a web browser via the Internet. COMET Cloud can inform about alarm conditions via e-mails or notifications using a mobile phone application (Android or iOS). Each Web Sensor comes with 3 months free trial period for COMET Cloud. It allows to test features of COMET Cloud without any additional costs. To be device visible at COMET Cloud, it needs to be registered into Cloud. This can be done by the procedure described at registration card. Registration card is part of original package.

COMET database

Comet database provide a complex solution for data acquisition, alarm monitoring and measured data analyzing from Comet devices. Central database server is based on MS SQL technology. Client-server conception allows to easy and instant access to data. Data are accessible from multiple places by the Database Viewer software. One license of Comet Database includes also one license for Database Viewer.