

PRODUCT DESCRIPTION

The COMETEO radiation shield F8000 is designed for protect the COMET temperature and relative humidity sensor from thermal radiation and climatic influences.

DIMENSIONS

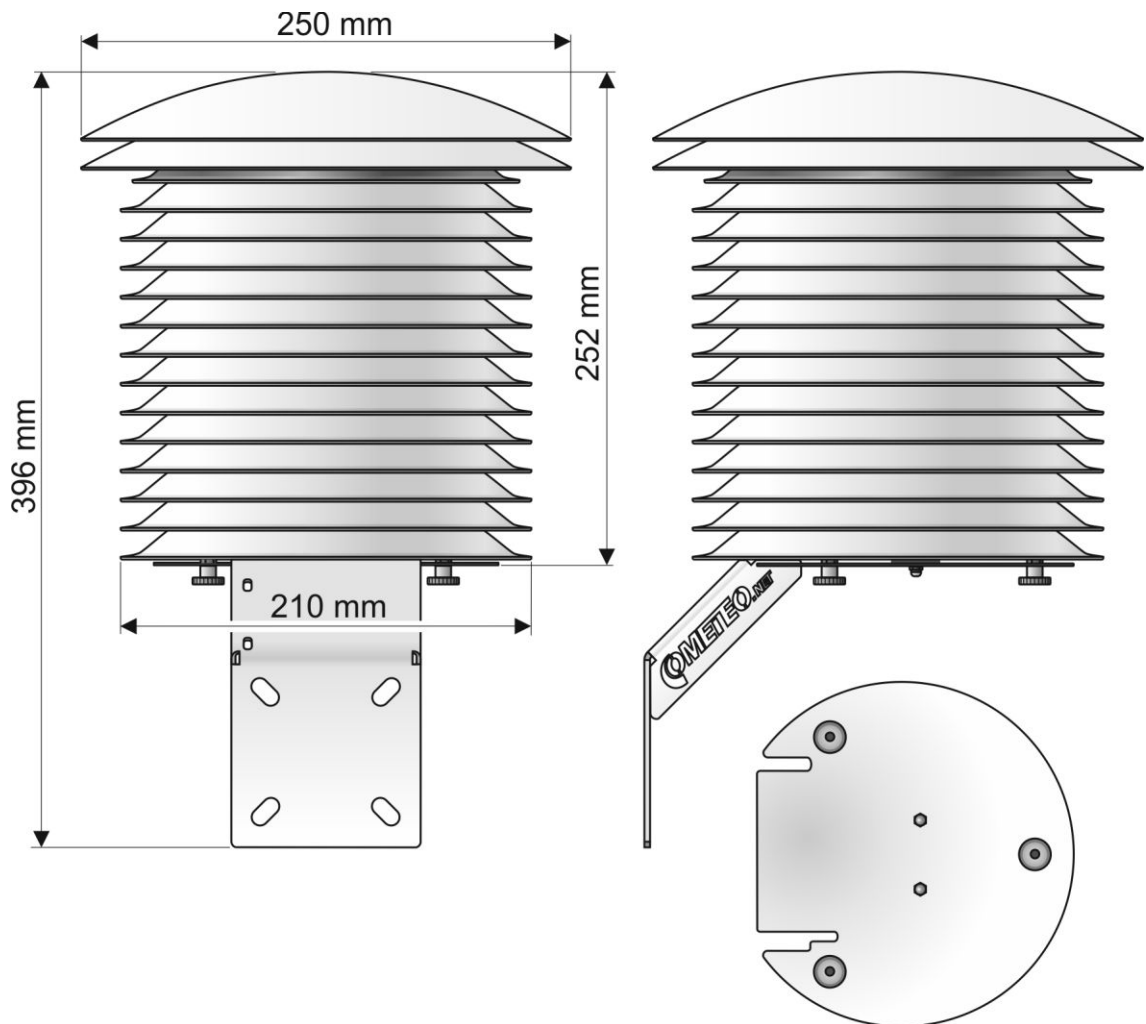

RADIATION SHIELD LOCATION

Place the radiation shield at least 1.8 m above the ground. If it is necessary to mount the shield in close proximity to the building, it should be on its north (shaded) side. For professional measurements, a grass place is recommended that has no obstacles within a radius of 10 m (the lawn should be maintained on an ongoing basis). The distance to the nearest building should be more than four times the height of the building.

RADIATION SHIELD MOUNTING

The package includes two clamps for fixing the shield. Attach the clamps to a pipe with a diameter of 20 to 50 mm (vertical or horizontal) and then attach the shield with the enclosed M8 nuts (see figure). The pipe should not interfere with the space next to the shield.

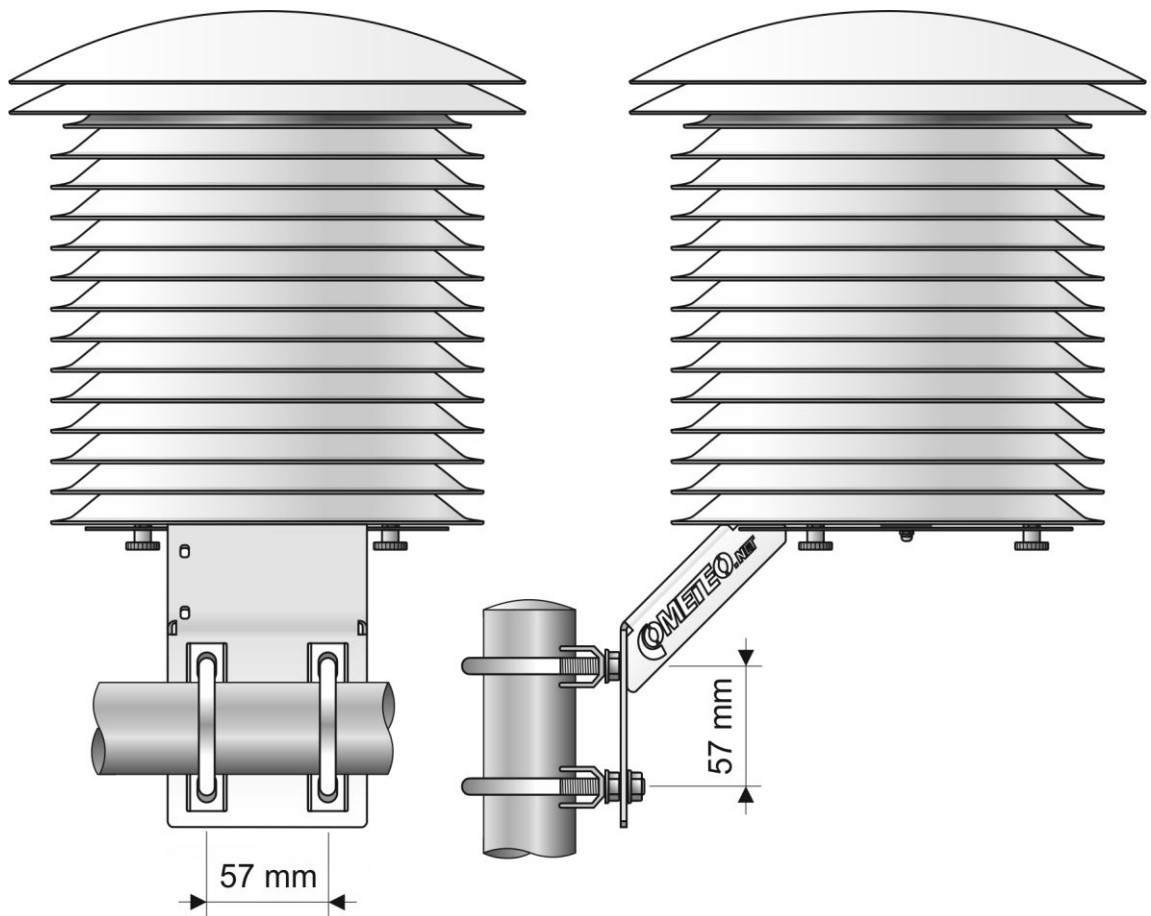

TRANSMITTERS AND MEASURING PROBES INSTALLATION

The internal space of the radiation shield with a diameter of 110 mm and a height of 210 mm allows the installation of a wide range of transmitters and probes. Use the mounting bracket included with the lower reflective plate to secure them. Unscrew the three lower nuts and slide the bracket out of the shield (see figure).

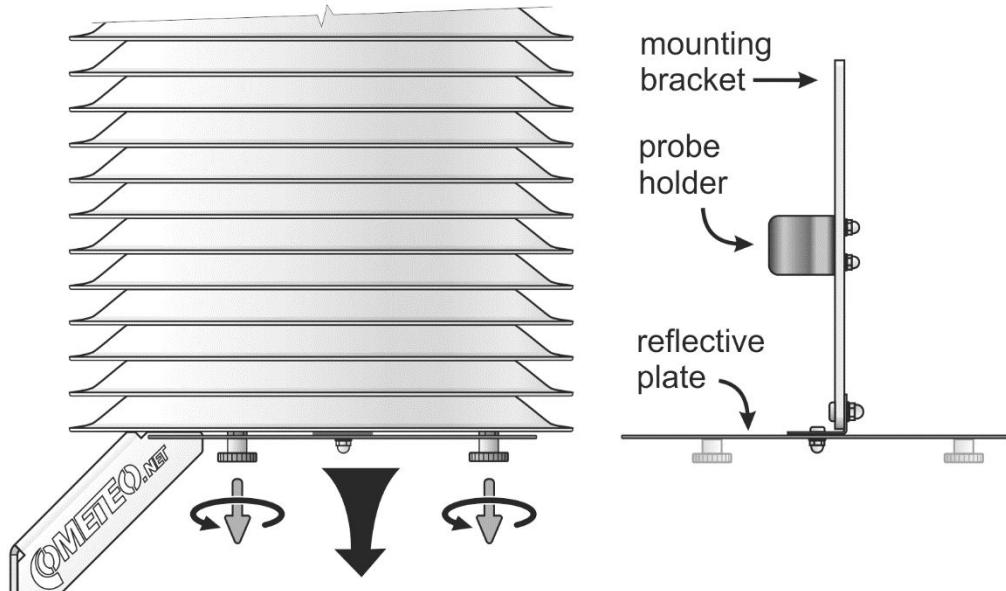

Measuring probe installation

Always install the probe sensor above the minimum installation height limit (dashed line in the figure). Start the installation from the probe sensor and then gradually place the cable in the slots as shown.

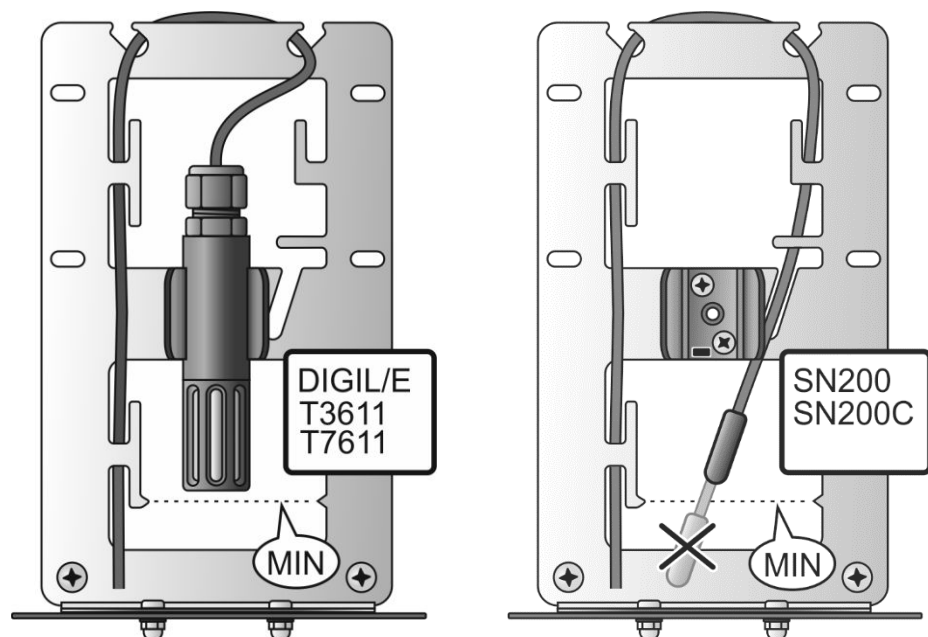

If the probe cable is too thin (approx. 2 to 3 mm, eg for the TG3 probe) and there is a risk of instability of the probe sensor, secure the probe cable by turning the probe holder. See pictures below.

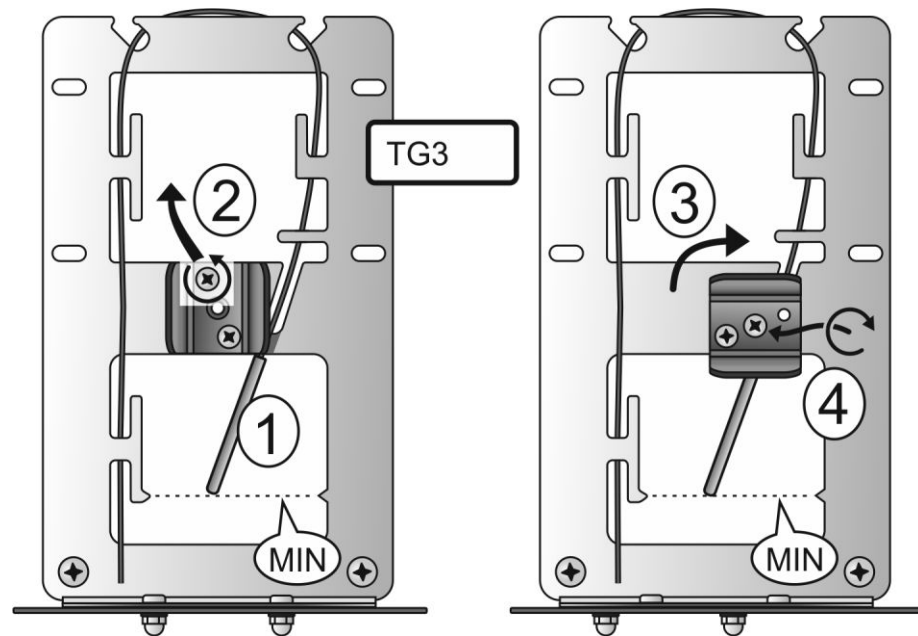

Installation of devices with cable connection

Unscrew the black probe holder and screw the device into the upper position of the mounting bracket with the supplied M4 screws.

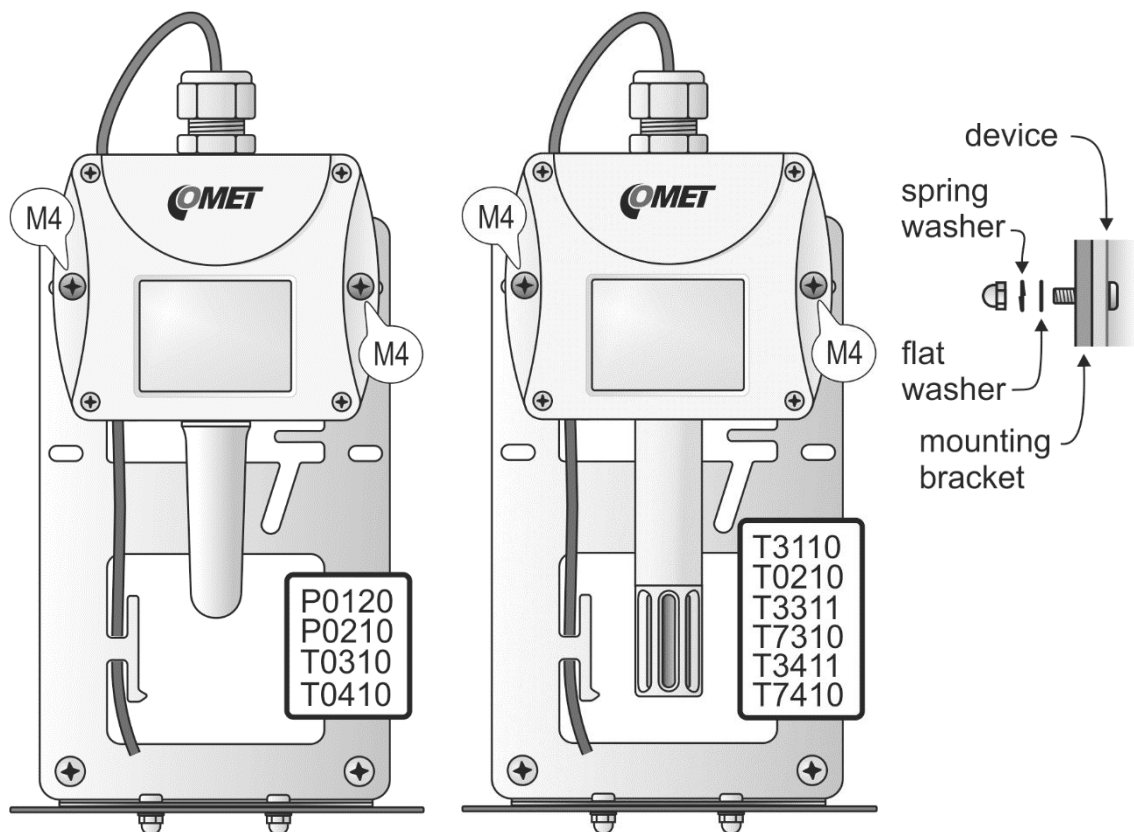

Installation of wireless transmitters

Unscrew the black probe holder and screw the transmitter into the correct position on the mounting bracket with the supplied M3 or M4 screws (see figure).

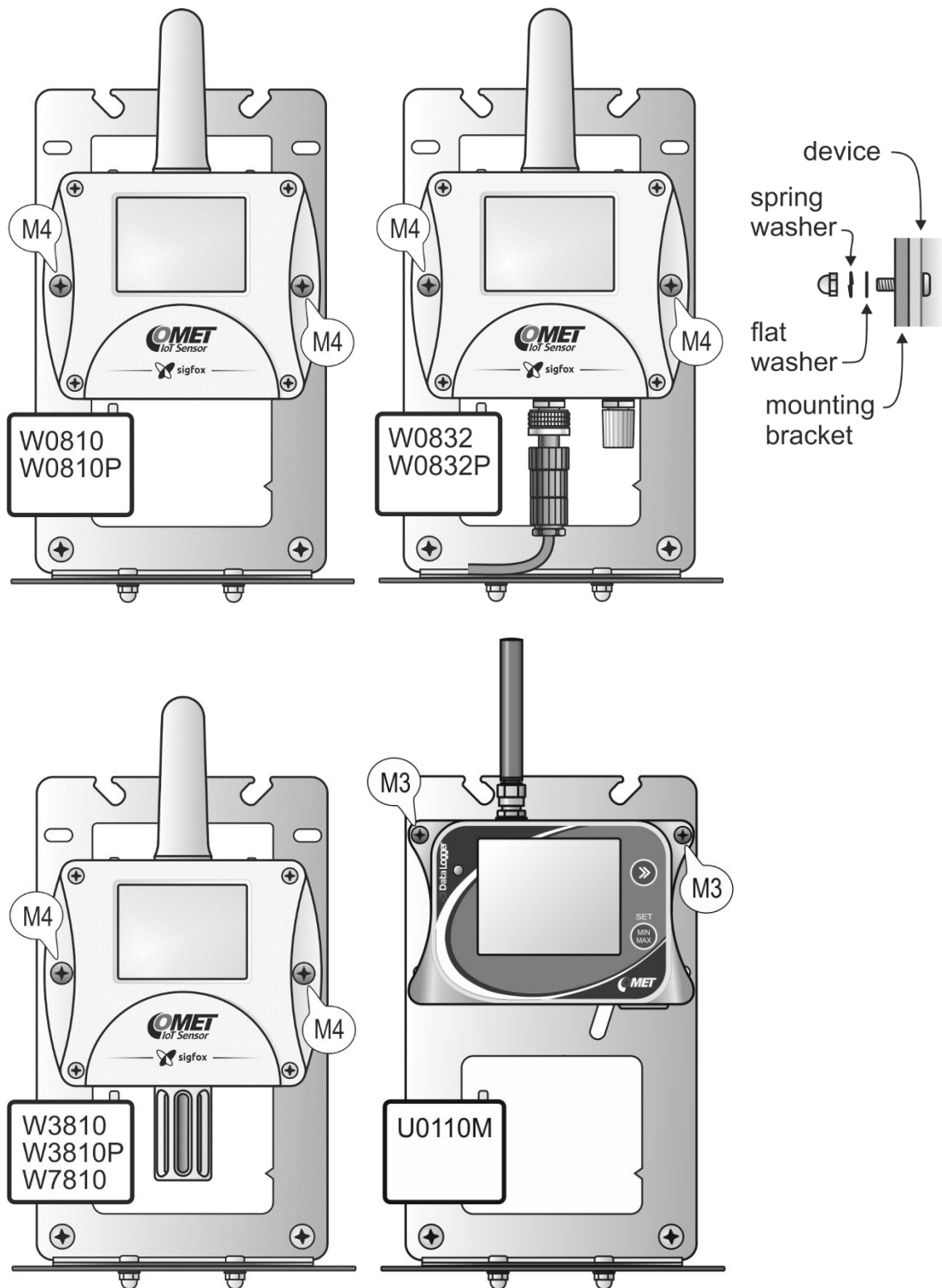

The SP015C Batteries holder installation

The Batteries holder is suitable for applications where the life of the transmitter internal battery is insufficient.

- connect the Battery holder connection adapter to the Wx8xx transmitter (see Battery holder SP015C manual)
- unscrew the black probe holder (1) from the shield mounting bracket, loosen the lower screws (2), turn the mounting bracket and reattach it in the position shown in the figure (3)

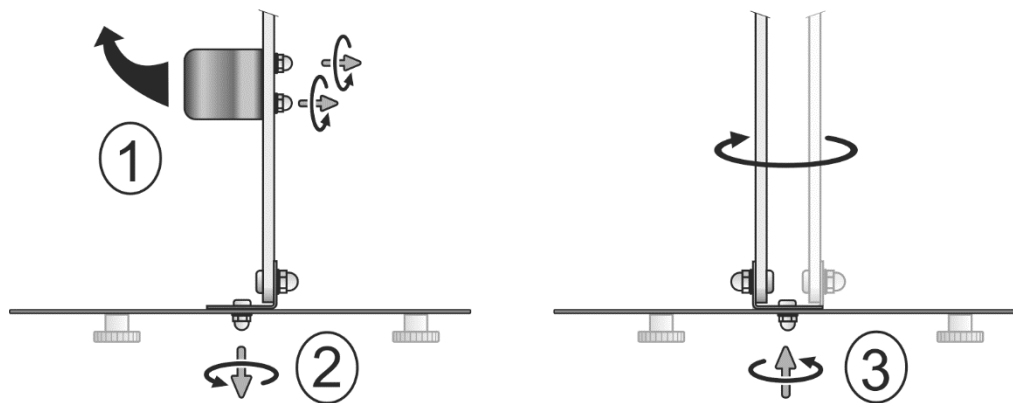

- fasten the Wx8xx transmitter (with the SP015C Batteries holder connected) with two M4 screws to the shield mounting bracket as shown. Longer screws are included in the SP015C delivery. The mounting bracket and both devices should now be exactly on the center axis of the shield interior space.

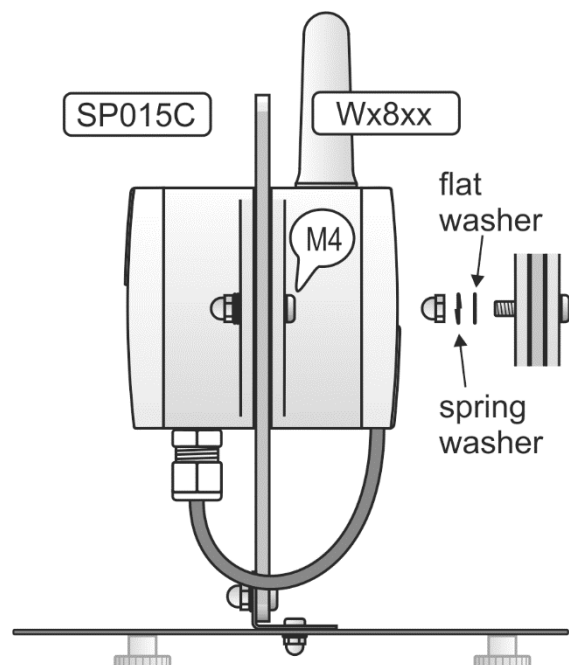

Installation of mounting bracket with device or probe

The figure shows an example of mounting the probe. Insert the reflective plate with the mounting bracket and the device into the shield and secure with three nuts. Use the space in the lower reflective plate to store the cable (see figure). Secure the cable with the enclosed cable ties.

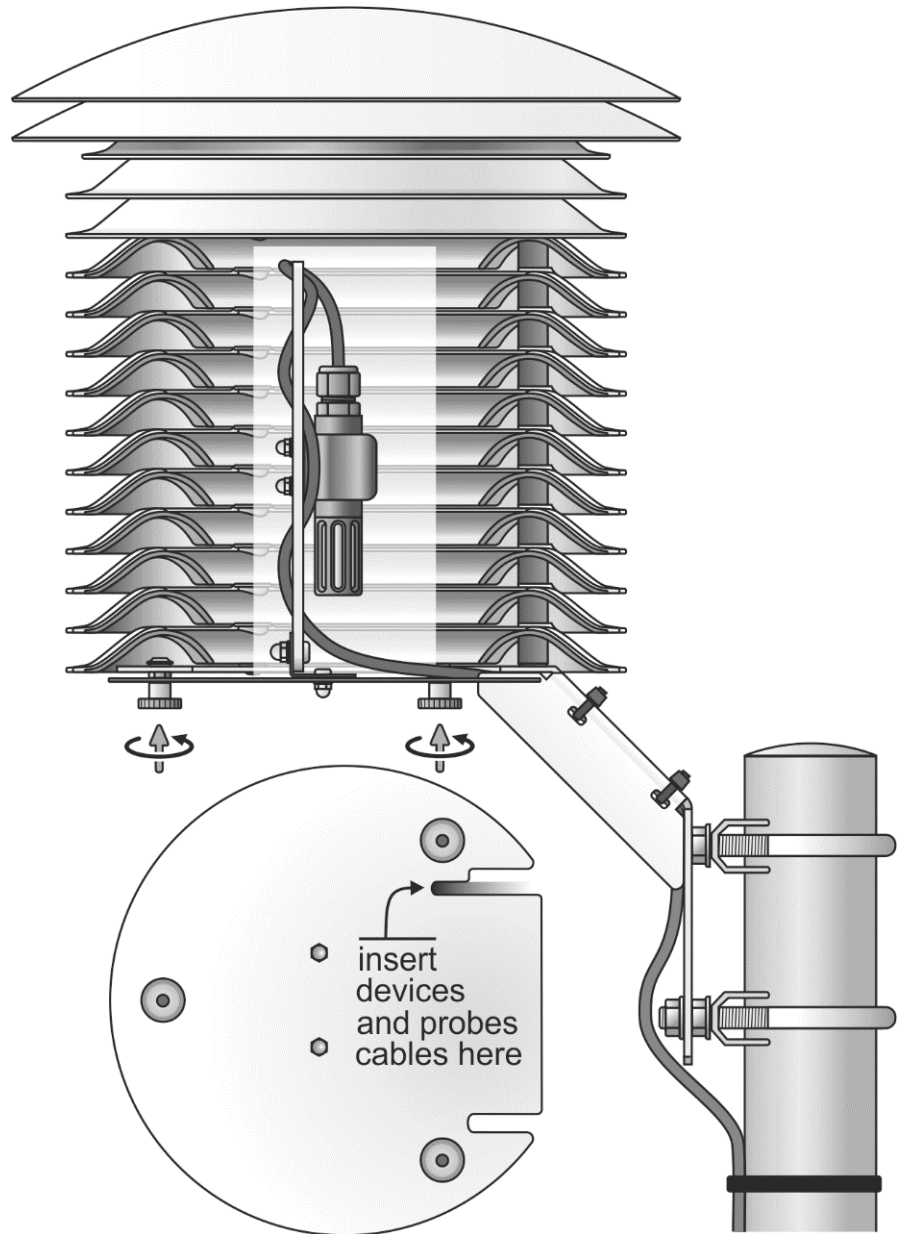

TECHNICAL SPECIFICATION

Temperature operating range:	-40 až +65 °C
Fixing the shield:	on a pipe with a diameter of 20 to 50 mm
Internal space:	diameter 110 mm, height 210 mm
Relative humidity operating range:	0 až 100 %RH
Storage temperature range:	-40 až +65 °C
Storage relative humidity range:	0 až 100 %RH (no condensation)
Weight:	approximately 2.4 kg (without mounting clamps)
Material:	UV stabilized ASA, stainless steel

CONTENT OF THE PACKAGE:

• shield F8000	1 pc
• mounting clamp	2 pcs
• cable tie	4 pcs
• nut M8	4 pcs
• screw M4 x 14 with nut M4	2 + 2 pcs
• screw M3 x16 with nut M3	2 + 2 pcs
• flat washer and spring washer 4,2 mm	2 + 2 pcs
• flat washer and spring washer 3,1 mm	2 + 2 pcs

END OF OPERATION

The radiation shield dispose according to current legislation.

TECHNICAL SUPPORT AND SERVICE

Technical support and service is provided by distributor. For contact see warranty certificate.

WARNING

Installation, commissioning and maintenance may only be carried out by personnel with qualification by applicable regulations and standards.

© Copyright: COMET SYSTEM, s.r.o.

It is prohibited to copy and make any changes in this manual, without explicit agreement of company COMET SYSTEM, Ltd. All rights reserved.

COMET SYSTEM, Ltd. makes constant development and improvement of their products. Manufacturer reserves the right to make technical changes to the device without previous notice. Misprints reserved.