

PRODUCT DESCRIPTION

The COMETEO radiation shield F8001 is designed for the protection of any temperature and humidity sensor with a diameter of 13 to 18 mm from thermal radiation and climatic influences.

DIMENSIONS

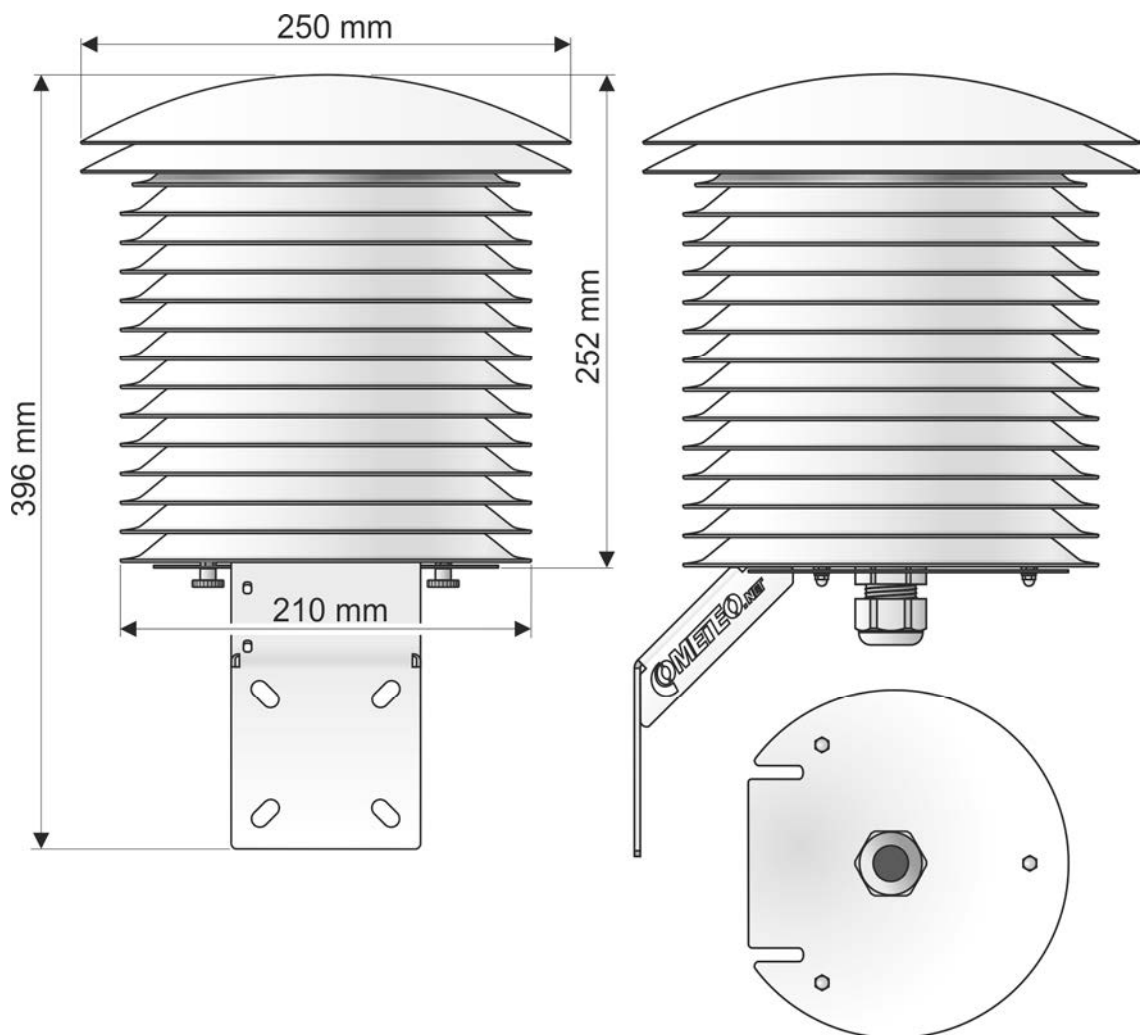

RADIATION SHIELD LOCATION

Place the radiation shield at least 1.8 m above the ground. If it is necessary to mount the shield in close proximity to the building, it should be on its north (shaded) side. For professional measurements, a grass place is recommended that has no obstacles within a radius of 10 m (the lawn should be maintained on an ongoing basis). The distance to the nearest building should be more than four times the height of the building.

RADIATION SHIELD MOUNTING

The package includes two clamps for fixing the shield. Attach the clamps to a pipe with a diameter of 20 to 50 mm (vertical or horizontal) and then attach the shield with the enclosed M8 nuts (see figure). The pipe should not interfere with the space next to the shield.

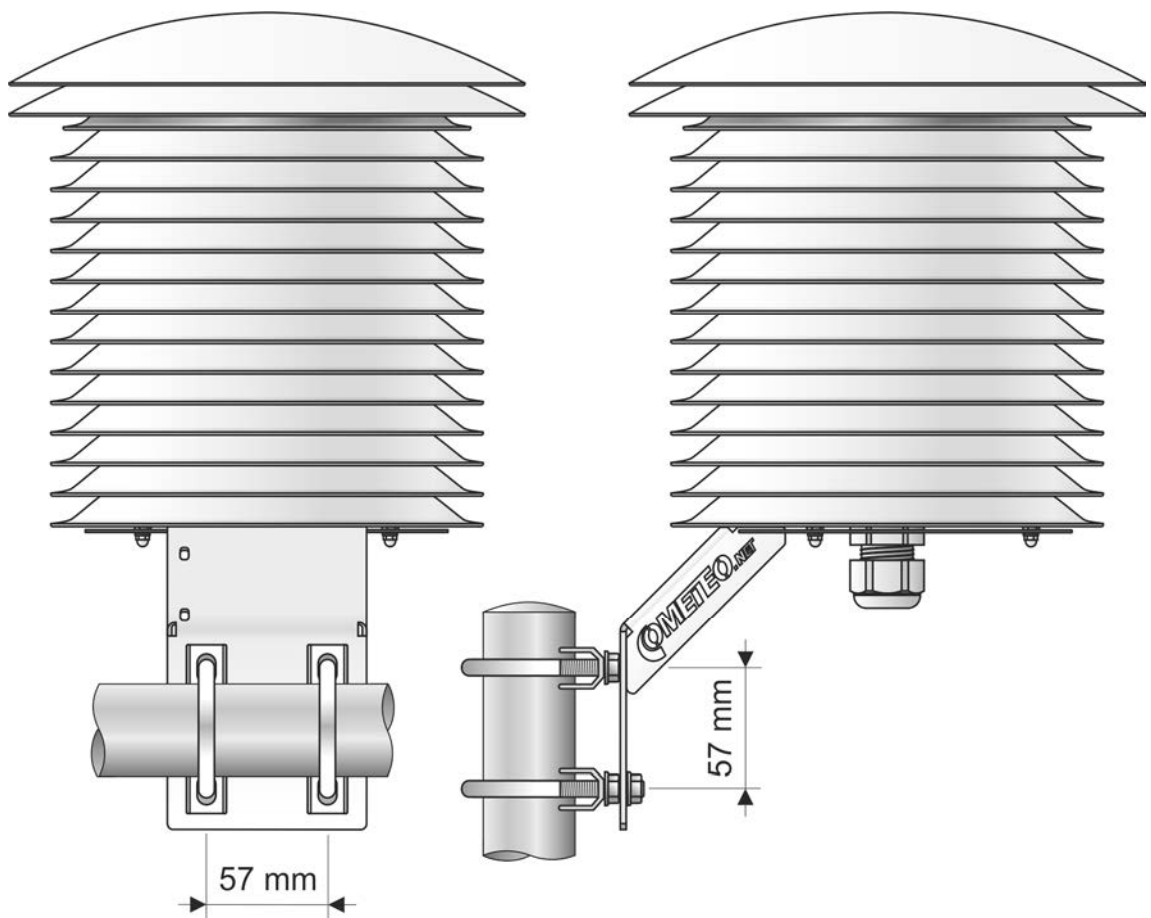

MEASURING PROBE INSTALLATION

Insert the measuring probes into the glands at the bottom of the shield to the recommended height (see figure) and and tighten the nut to secure the probe. Secure the cables with cable ties.

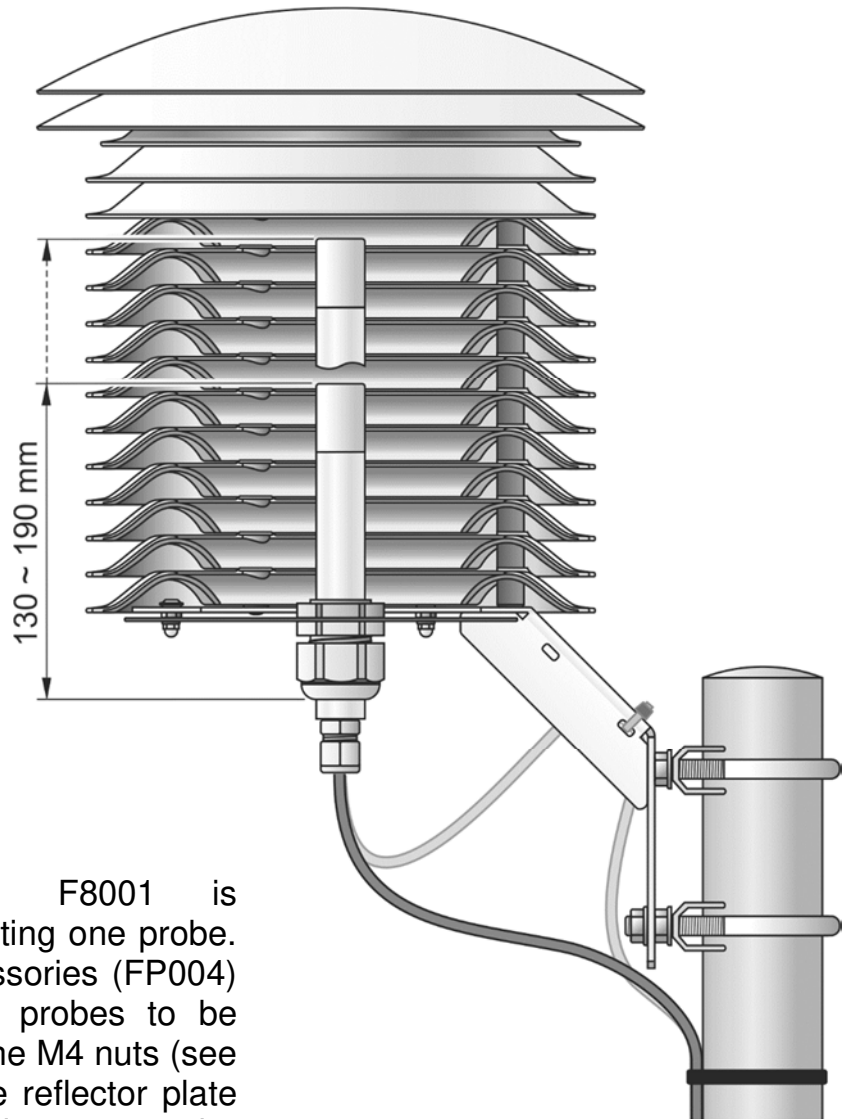

Radiation shield F8001 is designed for mounting one probe. The optional accessories (FP004) allows up to four probes to be installed. Loosen the M4 nuts (see figure), remove the reflector plate with the gland and screw on the plate with the four glands. Insert blanking plugs in unused glands.

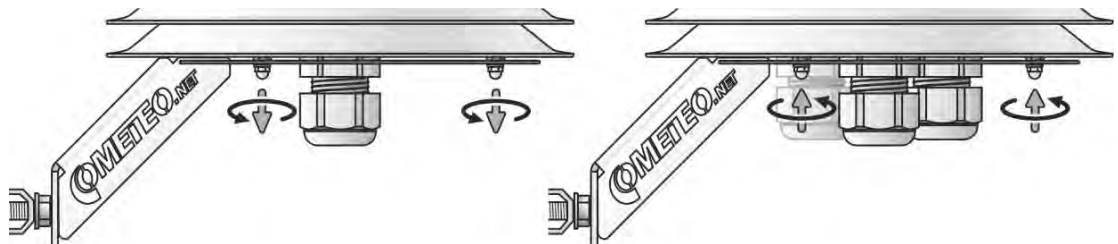

TECHNICAL SPECIFICATION

Diameter of the installed probe:	13 až 18 mm
Fixing the shield:	on a pipe with a diameter of 20 to 50 mm
Temperature operating range:	-40 až +65 °C
Relative humidity operating range:	0 až 100 %RH
Storage temperature range:	-40 až +65 °C
Storage relative humidity range:	0 až 100 %RH (no condensation)
Weight:	approximately 2.4 kg (without mounting clamps)
Material:	UV stabilized ASA, stainless steel

CONTENT OF THE PACKAGE:

- shield F8001 1 pc
- mounting clamp 2 pcs
- cable tie 4 pcs
- nut M8 4 pcs

END OF OPERATION

The radiation shield dispose according to current legislation.

TECHNICAL SUPPORT AND SERVICE

Technical support and service is provided by distributor. For contact see warranty certificate.

WARNING

Installation, commissioning and maintenance may only be carried out by personnel with qualification by applicable regulations and standards.

© Copyright: COMET SYSTEM, s.r.o.

It is prohibited to copy and make any changes in this manual, without explicit agreement of company COMET SYSTEM, Ltd. All rights reserved.

COMET SYSTEM, Ltd. makes constant development and improvement of their products. Manufacturer reserves the right to make technical changes to the device without previous notice. Misprints reserved.

ie-snc-F8001-01



Authorized Distributor in Australia & New Zealand
Pacific Sensor Technologies Pty Ltd
Unit 4, 3 Neutron Place Rowville, VIC 3178 Australia
1300 662 720 | sales@pacificsensortech.com.au
www.pacificsensortech.com.au