

PRODUCT DESCRIPTION

Programmable interior transmitters with 4 - 20 mA or 0 - 10 V outputs are designed for measurement of CO₂ concentration in air and for measurement of air temperature in exacting interiors in building energy management and HVAC systems.

The CO₂ concentration is measured using the dual wavelength NDIR sensor with multiple point adjustment. This principle compensates aging of the sensing elements and guarantees outstanding high reliability and long-term stability of the measurement.

Measured values are displayed on a two-line LCD display. The device is also equipped with three-color LED for visual indication of the CO₂ concentration. Using *TSensor* software (see www.cometsystem.com) you can set up measuring range of device output, measurement mode of CO₂ concentration and limits of CO₂ LED indication. For device connection to USB port of PC is used SP003 cable (optional accessories). The connector for SP003 cable connection is situated on the front part of the device near the info-button.

Transmitters are designed for easy installation on ordinary KU68 wiring boxes with using two enclosed mounting screws.

type *	output	measured values	construction	mounting
T8148	2 x 4-20mA	T + CO ₂	ambient air	wall
T8248	2 x 0-10V	T + CO ₂	ambient air	wall

* models marked TxxxxZ are custom - specified devices

T...temperature, CO₂...concentration of CO₂ in air

INSTALLATION AND OPERATION

For correct function there is necessary to find proper device place. It shouldn't be placed at places where it can be affected by sunshine, near radiators, heating elements and other heat sources, air handlers, windows, doors, into racks and shelves and similar places. For buildings with less thermal insulation there is not suitable to place them on external walls of building. If there are communication conductors placed into conduit, there is strongly recommended make it caulk, to restrict air flow around device.

Current outputs 4 - 20 mA (transmitter T8148) can be galvanically isolated or galvanically non-isolated. Configuration jumpers (see schematic diagram) are located on the front part of the device. Voltage outputs 0 - 10 V (transmitter T8248) are not galvanically isolated.

Firstly mount back part of device onto wiring box with two holding screws. Connect cables to terminals and finally insert front part of device (installation procedure see next page). For transmitter connection it is recommended to use shielded cable. Maximum cable length of the current loop is 1200m, maximum voltage output cable length is 15m. All cables should be located as far as possible from potential interference sources.

After powering on the device starts the internal test. During this time LCD display shows ---- instead of CO₂ concentration value.

Devices don't require special operation and maintenance. We recommend you periodic calibration for measurement accuracy validation.

INFO MODE

The output range settings can be verified without a use of the computer by pressing button on the left side of the device (see picture). For button pressing use thin instrument (paper clip etc.). First short press shows low range and type of measured value for I1 output. Next button press shows values for upper scale limit (the same channel, the same value). I2 output settings are displayed similarly. No measurement and communication is possible during info mode. If device stays in info mode for longer than 15 s, device automatically returns to measuring cycle.

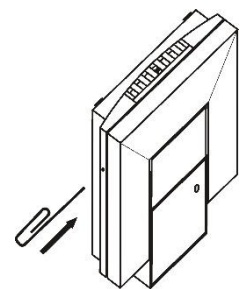

ERROR STATES

Device continuously checks its state during operation and if an error appears, it is displayed relevant code:

Err 2 - CO₂ concentration or temperature measurement error occurred

Err 0, Err 1, Err 3 and Err 4 - it is a serious error, please contact distributor of the device

SAFETY INSTRUCTIONS



- Don't connect or disconnect transmitter while power supply voltage is on.
- Don't use the device in an explosive environment.
- Devices are not designed for locations with chemically aggressive environment.
- Installation, electrical connection and commissioning should be performed by qualified personnel only.
- Devices contain electronic components, it needs to liquidate them according to currently valid conditions.
- **To supplement the information** provided in this data sheet, use the manuals and other documentations which are available at www.cometsystem.com.

Technical specifications

Device type	T8148	T8248
Analog output *	4 - 20 mA	0 - 10 V
Supply voltage U _{ss} / power consumption / max. power consumption **	9 - 30 Vdc / 1W / 4W	15 - 30 Vdc / 0,5W / 3W
Output in case of error	< 3.8mA or > 24mA	< -0.1V or > 10.5V
Temperature measuring range	-10 to +50°C	-10 to +50°C
Accuracy of temperature measurement	± 0.5°C	± 0.5°C
CO ₂ concentration measuring range ***	0 to 2000 ppm	0 to 2000 ppm
Accuracy of CO ₂ concentration measurement at 25°C and 1013 hPa	± (50ppm+2% of measured value)	± (50ppm+2% of measured value)
Temperature dependence of CO ₂ concentration measurement at 0 to 50°C	typ. 2 ppm CO ₂ /°C	typ. 2 ppm CO ₂ /°C
Recommended calibration interval - temperature / CO ₂	2 years / 5 years	2 years / 5 years
Protection class of the case with electronics	IP20	IP20
Temperature operating range of the case with electronics	-10 to +50°C	-10 to +50°C
Humidity operating range (no condensation)	5 to 95%RH	5 to 95%RH
Atmospheric pressure operating range	850 to 1100 hPa	850 to 1100 hPa
Storage temperature range (5 to 95%RH, pressure 700 to 1100 hPa)	-30 to +80°C	-30 to +80°C
Electromagnetic compatibility according to	EN 61326-1	EN 61326-1
Weight	150 g	150 g

Electrical wiring

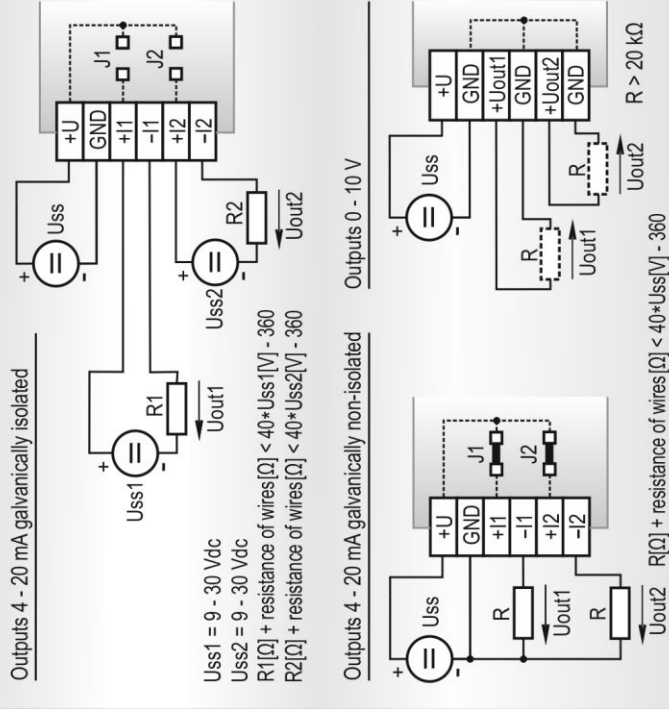

* device setting from the manufacturer: output 1 - CO₂ concentration, output 2 - temperature
 ** for 50 ms with 15 s period

Device installation

Device mounting

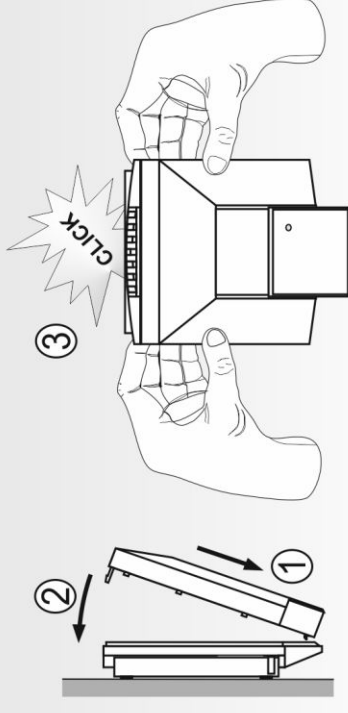

Device demounting

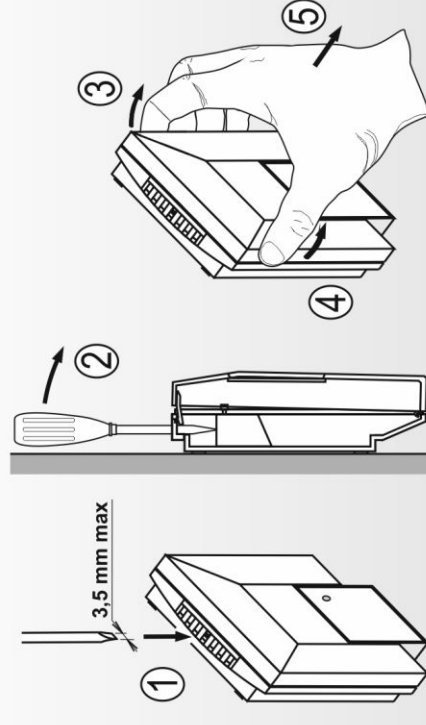

Dimensions

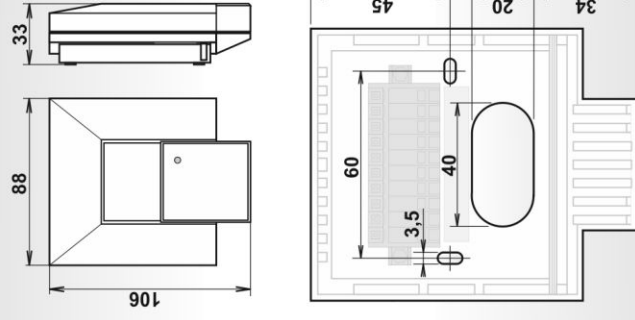

*** LED indication (preset by manufacturer): **green** (0 to 1000 ppm), **yellow** (1000 to 1200 ppm), **red** (1200 to 2000 ppm)